

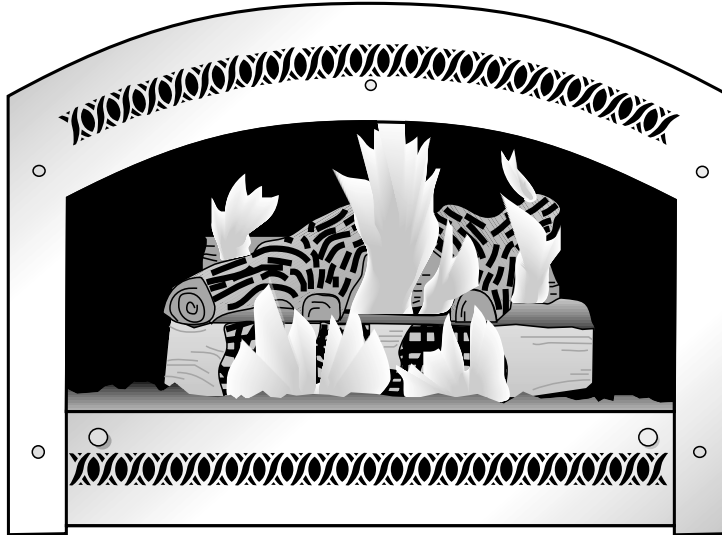

FIREPLACE XTROORDINAIR™



Featuring the



Burner

Tested and Listed by



Omni-Test Laboratories, Inc.
Beaverton, Oregon
Report# 028-S-20b-1
ANSI Z21.88, CSA 2.33 MR8,
CAN/CGA 2.17-M91

- Built-In Direct Vent Fireplace
- Natural Gas or Propane
- Residential or Mobile Home

WARNING: Improper installation, adjustment, alteration, service or maintenance can cause injury or property damage. Refer to this manual. For assistance or additional information consult a qualified installer, service agency, or the gas supplier.

- Do not store or use gasoline or other flammable vapors and liquids in the vicinity of this or any other appliance.
- Installation must be performed by a qualified installer, service agency or the gas supplier

IF YOU SMELL GAS

- Do not try to light any appliance.
- Do not touch any electrical switch; do not use any phone in your building.
- Immediately call gas supplier from a neighbor's phone. Follow the gas supplier's instructions.
- If you cannot reach your gas supplier, call the fire department.

36 DV EFII Owner's Manual

Installer: After installation give this manual to the home-owner and explain operation of this fireplace.



\$10.00

© Copyright 2005 Travis Ind.

100-01160

4050923

TRAVIS INDUSTRIES
HOUSE OF FIRE
4800 Harbour Pointe Blvd. SW
Mukilteo, WA 98275

Introduction

We welcome you as a new owner of a Fireplace Xtordinaire gas fireplace. In purchasing a Fireplace Xtordinaire you have joined the growing ranks of concerned individuals whose selection of an energy system reflects both a concern for the environment and aesthetics. The Fireplace Xtordinaire is one of the finest home heaters the world over. This manual will explain the installation, operation, and maintenance of this fireplace. Please familiarize yourself with the Owner's Manual before operating your heater and save the manual for future reference. Included are helpful hints and suggestions that will make the operation and maintenance of your new fireplace an easier and more enjoyable experience. We offer our continual support and guidance to help you achieve the maximum benefit and enjoyment from your heater.

Important Information

No other Fireplace Xtordinaire gas fireplace has the same serial number as yours. The serial number is below and to the left of the gas control valve.

This serial number will be needed in case you require service of any type.

Model: 36 DV EFIII

Serial Number: _____

Purchase Date: _____

Purchased From: _____

Mail your Warranty Card Today, and Save Your Bill of Sale.

To receive full warranty coverage, you will need to show evidence of the date you purchased your heater. Do not mail your Bill of Sale to us.

We suggest that you attach your Bill of Sale to this page so that you will have all the information you need in one place should the need for service or information occur.

**NATIONAL
FIREPLACE
INSTITUTE**



CERTIFIED
www.nficertified.org

We suggest that our gas hearth products be installed and serviced by professionals who are certified in the U.S. by the National Fireplace Institute® (NFI) as NFI Gas Specialists.

Introduction

Introduction & Important Information.....2

Safety Precautions

Safety Precautions4

Features & Specifications

Features6
 Installation Options.....6
 Heating Specifications.....6
 Dimensions.....6

Installation

Installation Warning.....7
 Packing List.....7
 Additional Items Required for Installation.....7
 Installation Overview.....7
 Fireplace Placement Requirements.....8
 Minimum Framing Dimensions8
 Clearances8
 Corner Installations9
 Raised Fireplaces.....9
 Hearth Requirements.....10
 Facing Requirements.....11
 Facing Over 1" Thick.....11
 Facing Detail.....12
 Face Dimensions13
 Rectangular Faces.....14
 Facing and Hearth Examples.....14
 Mantel Requirements.....16
 Vent Requirements.....17
 Altitude Considerations17
 Clearances17
 Use of 8" Dia. Pipe.....17
 Part Numbers for 6-5/8" Dia. Pipe.....17
 Vent Installation.....18
 Approved Vent Configurations.....19
 Restrictor Position.....19
 Elbows.....19
 Measuring Vent Lengths.....19
 Vertical Term. 0,2 or 4 45° Offsets (6-5/8")....20
 Hor. Terminations with 6-5/8" Dia. Vent21
 Vert. Term. with 2 or 3 Elbows (6-5/8" Dia.)....22
 Horizontal Terminations with 8" Dia. Vent.....23
 Vent Termination Requirements24
 Gas Line Requirements.....25
 Fuel.....25
 Gas Line Connection.....25
 Gas Inlet Pressure25
 Electrical Connection.....26

Finalizing the Installation

1 Glass Frame Removal (& installation).....27
 2 Log & Coal Installation29
 3 Leak Test.....31
 4 Replace the Glass31
 5 Faceplate Installation.....31
 6 Pilot Adjustment (if necessary).....31
 7 Air Shutter Adjustment (if necessary)31
 8 Check Flame.....32
 9 Explain Operation to Home-Owner.....32

Operation

Before You Begin.....33
 Location of Controls33
 Starting The Pilot34
 Starting the Fireplace for the First Time.....35
 Turning the Fireplace On and Off.....35
 Adjusting the Flame Height.....35
 Adjusting the Blower Speed.....36
 Normal Operating Sounds.....36
 Normal Operating Odors.....36

Maintenance

Yearly Service Procedure.....37
 Troubleshooting Table.....38
 How this Fireplace Works.....39
 What Turns the Main Burners On and Off.....39
 What Prevents Gas Buildup.....39
 Wiring Diagram40
 Replacement Parts List.....40

Safety Label

Safety (Listing) Label.....41

Warranty

Warranty.....42

Optional Equipment

LP Conversion Kit43
 Power Heat Duct.....46

Index

Index.....52

Safety Precautions

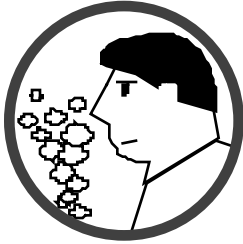

• IF YOU SMELL GAS:

- * Do not light any appliance
- * Extinguish any open flame
- * Do not touch any electrical switch or plug or unplug anything
- * Open windows and vacate building
- * Call gas supplier from neighbor's house, if not reached, call fire department



- This unit must be installed by a qualified installer to prevent the possibility of an explosion. Your dealer will know the requirements in your area and can inform you of those people considered qualified. The room heater should be inspected before use and at least annually by a qualified service person. More frequent cleaning may be required due to excessive lint from carpeting, bedding material, etc.
- The instructions in this manual must be strictly adhered to. Do not use makeshift methods or compromise in the installation. Improper installation will void the warranty and safety listing.

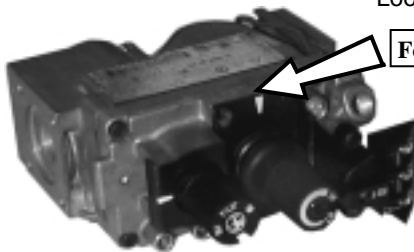

Look for this label:

For LPG only | Pout 11" W.C.

If the label is present, the heater is equipped for LP (propane). If the label is absent, the heater is equipped for NG (natural gas).

- This heater is either approved for natural gas (NG) or for propane (LP). Burning the incorrect fuel will void the warranty and safety listing and may cause an extreme safety hazard. Direct questions about the type of fuel used to your dealer. Check the label and flame adjust knob on the gas control valve.



- Contact your local building officials to obtain a permit and information on any installation restrictions or inspection requirements in your area. Notify your insurance company of this heater as well.



- If the flame becomes sooty, dark orange in color, or extremely tall, do not operate the heater. Call your dealer and arrange for proper servicing.

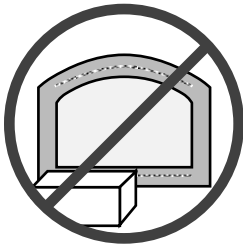

- It is imperative that control compartments, screens, or circulating air passageways of the heater be kept clean and free of obstructions. These areas provide the air necessary for safe operation.



- Do not operate the heater if it is not operating properly in any fashion or if you are uncertain. Call your dealer for a full explanation of your heater and what to expect.



- Do not store or use gasoline or other flammable liquids in the vicinity of this heater.

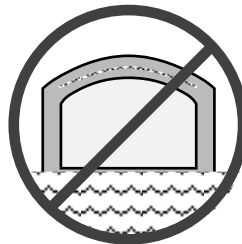

- Do not operate if any portion of the heater was submerged in water or if any corrosion occurs.

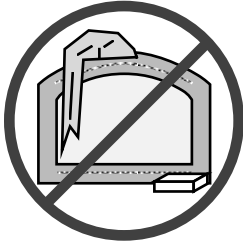

- Do not place clothing or other flammable items on or near the heater. Because this heater can be controlled by a thermostat there is a possibility of the heater turning on and igniting any items placed on or near it.

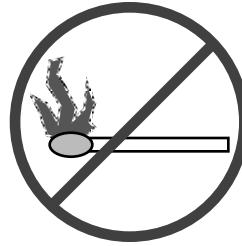

- Light the heater using the built-in piezo igniter. Do not use matches or any other external device to light your heater.
- Never remove, replace, modify or substitute any part of the heater unless

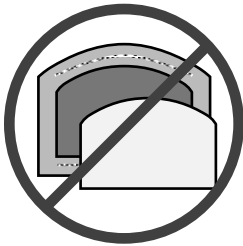

- The viewing glass should be opened only for lighting the pilot or conducting service.
- Any safety screen or guard removed for servicing must be replaced prior to operating the heater.

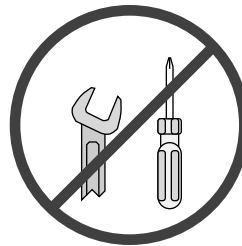

- instructions are given in this manual. All other work must be done by a trained technician. Don't modify or replace orifices.
- Allow the heater to cool before carrying out any maintenance or cleaning.



- Operate the heater according to the instructions included in this manual.
- If the main burners do not start correctly turn the gas off at the gas control valve and call your dealer for service.

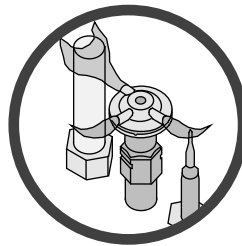

- The pilot flame must contact the thermopile and thermocouple (see the illustration to the left). If it does not, turn the gas control valve to "OFF" and call your dealer.

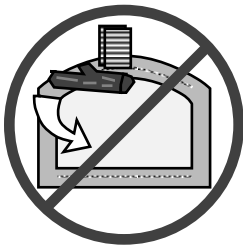

- This unit is not for use with solid fuel
- Do not place anything inside the firebox (except the included fiber logs).
- If the fiber logs become damaged, replace with Travis Industries log set.



- Do not throw this manual away. This manual has important operating and maintenance instructions that you will need at a later time. Always follow the instructions in this manual.



- Do not touch the hot surfaces of the heater. Educate all children of the danger of a high-temperature heater. Young children should be supervised when they are in the same room as the heater.

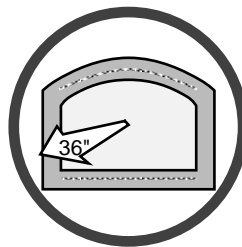

- Keep all furniture or other combustible items at least 36" away from the front of the fireplace (this includes drapes or doors that may swing within 36" of the front of the fireplace).

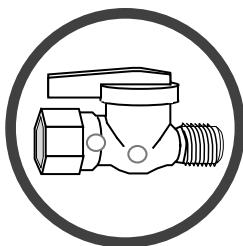

- Instruct everyone in the house how to shut gas off to the appliance and at the gas main shutoff valve. The gas main shutoff valve is usually next to the gas meter or propane tank and requires a wrench to shut off.



- Travis Industries, Inc. grants no warranty, implied or stated, for the installation or maintenance of your heater, and assumes no responsibility of any consequential damage(s).**

Features and Specifications

Features:

- Works During Power Outages (millivolt system)
- High Efficiency
- Optional Thermostat or Remote Control
- Realistic "Wood Fire" Look
- Quiet Blower for Effective Heat Distribution
- Convenient Operating Controls
- Variable-Rate Heat Output
- Low Maintenance

Installation Options:

- Residential or Mobile Home
- Straight or Corner Placement
- Flush or Recessed Face
- Raised or Floor Hearth
- Internal or External Chase
- Horizontal or Vertical Vent
- Power Heat Duct

Heating Specifications:

Approximate Heating Capacity (in square feet)*
 Maximum BTU Input Per Hour
 Minimum BTU Output on Low (with blowers on)
 Efficiency** (with blowers on)
 AFUE (Annual Fuel Utilization Efficiency)

Natural Gas

1,200 - 2,250
 43,000
 23,384
 Up to 79%
 72%

Propane

1200 - 2,250
 43,000
 20,800
 Up to 80%
 73%

* Heating capacity will vary with floor plan, insulation, use of Power Heat Duct, and outside temperature.

** Efficiency rating is a product thermal efficiency rating determined under continuous operation independent of installed system.

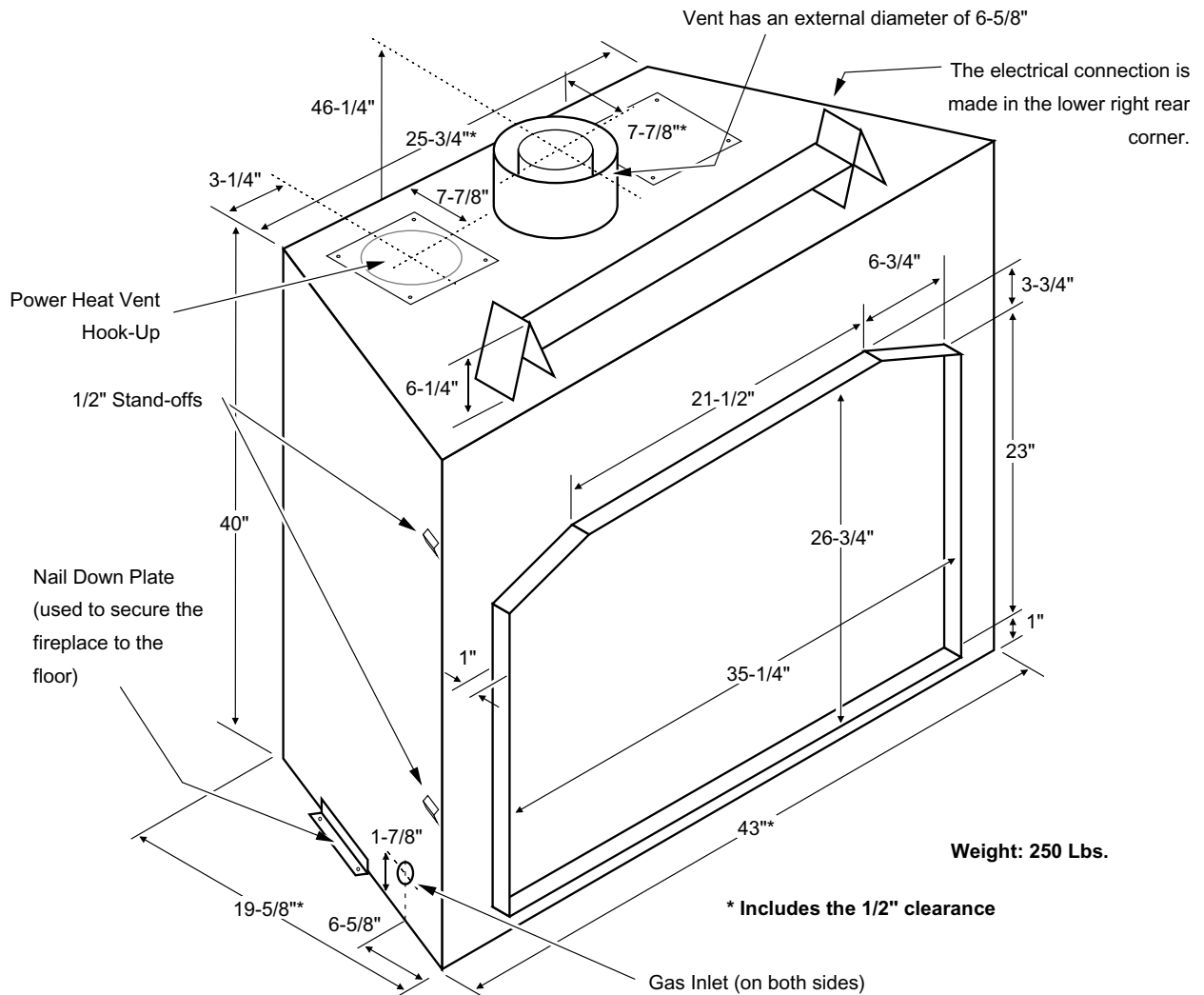

Installation Warnings:

- ! Failure to follow all of the requirements may result in property damage, bodily injury, or even death.
- ! This heater must be installed by a qualified installer who has gone through a training program for the installation of direct vent gas appliances.
- ! This appliance must be installed in accordance with all local codes, if any; if not, in U.S.A. follow ANSI Z223.1 and NFPA 54(88), in Canada follow B-149.
- ! In Manufactured or Mobile Homes must confirm with: In USA, Manufactured Home Construction and Safety Standard, Title 24 CFR, Part 3280; In Canada, CSA Z240.4 and Gas-Equipped Recreational Vehicles and Mobile Housing. This appliance may be installed in Manufactured Housing only after the home is site located.
- ! The 36DV is designed to operate on natural gas, or propane (LP).
All exhaust gases must be vented outside the structure of the living-area.
Combustion air is drawn from outside the living-area structure.
- ! Notify your insurance company before hooking up this fireplace.
- ! The requirements listed below are divided into sections. All requirements must be met simultaneously. The order of installation is not rigid – the qualified installer should follow the procedure best suited for the installation.

Packing List

- Propane Conversion Kit
- Log Set (Log Set, Coals, & Pins)
- Flex Tube with Pipe Adapter
- Glass Latch Tool (to un-latch glass frame)
- Arch Covers (for arched faces only)

Additional Items Required

- Faceplate (gold or black) - Includes attachment screws
- Direct Vent (Simpson Dura-Vent Ph. # 800 835-4429)
- Gas Line Equipment (shutoff valve, pipe, etc.)
- Electrical Equipment (min. 18 gauge, grounded line)

Installation Overview

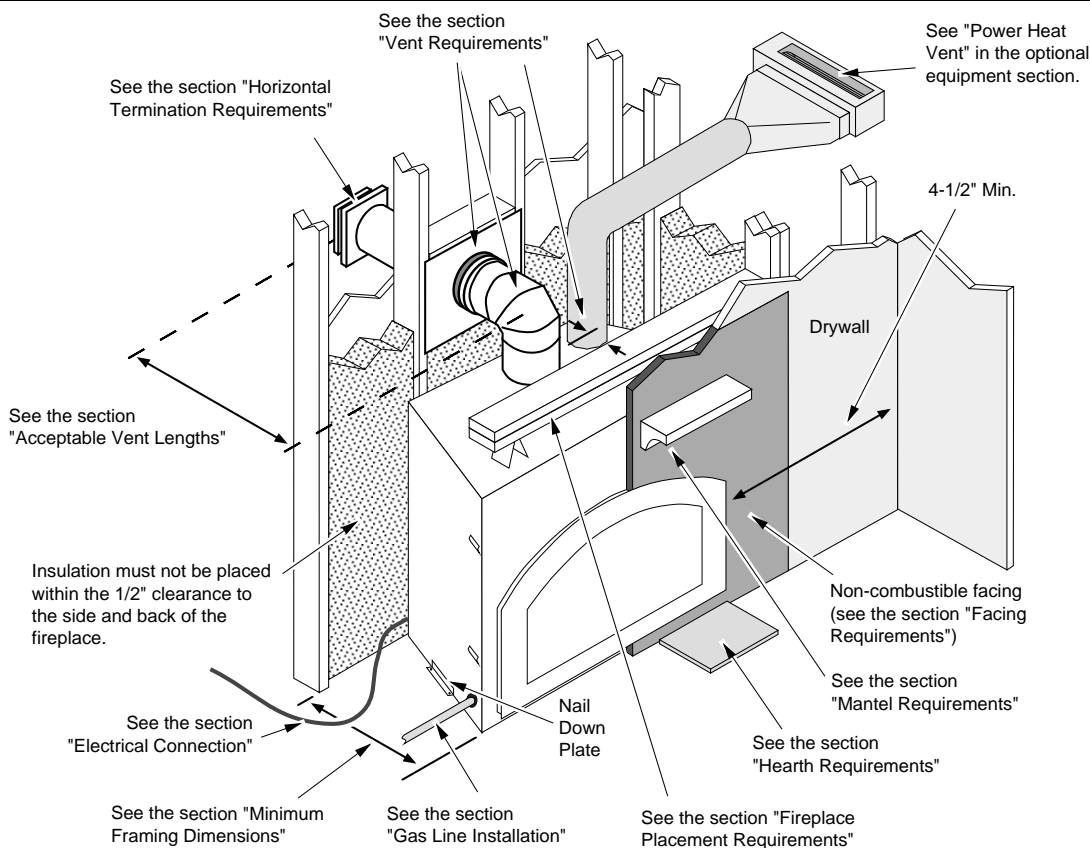

Fireplace Placement Requirements

Minimum Framing Dimensions

A 1/2" clearance is required along the sides and back of the fireplace. The 1/2" stand-offs on the sides and 6-1/4" stand-offs on the top of the fireplace are designed to separate the fireplace from the framing members. These stand-offs may contact the framing members but no material may be placed between the stand-offs.

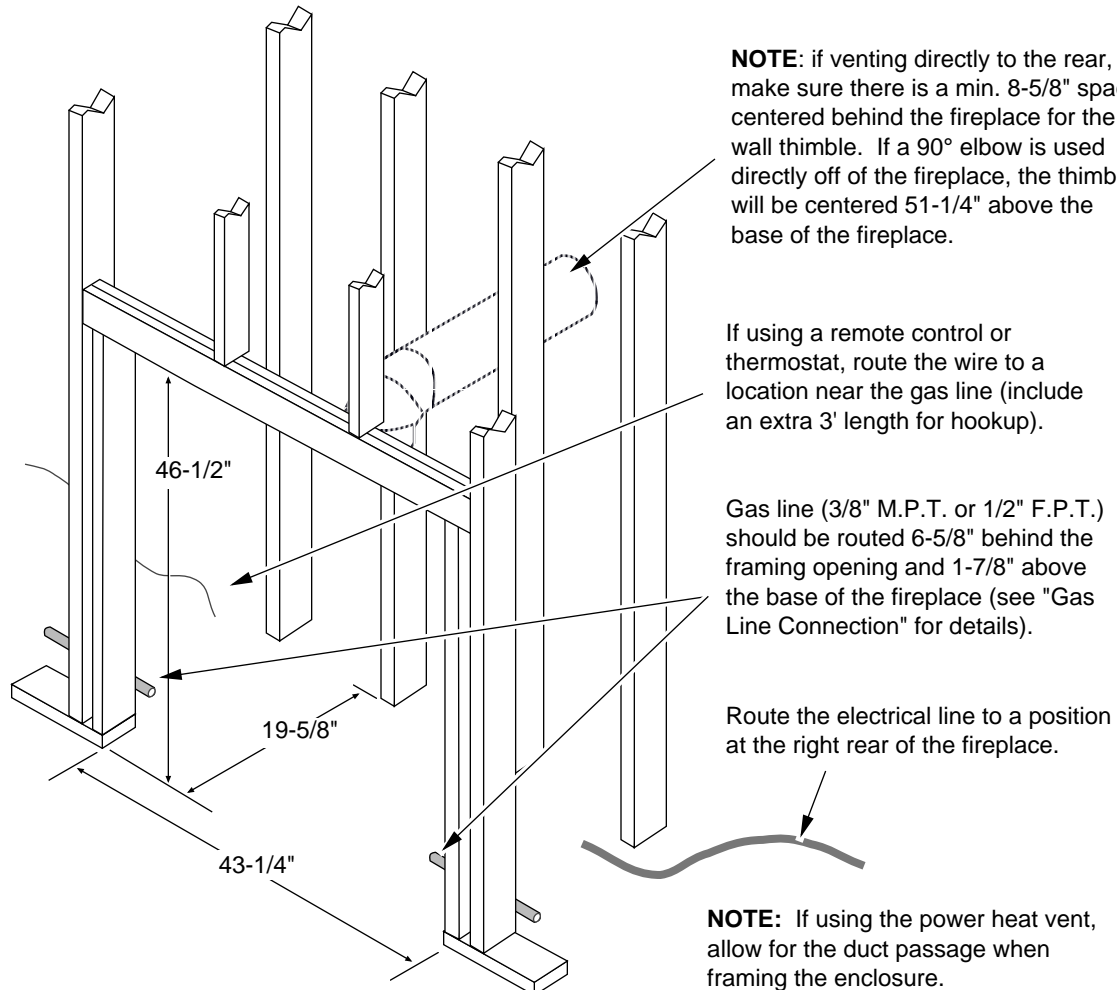

- Fireplace must be installed on a level surface capable of supporting the fireplace and vent
- Fireplace must be placed directly on wood or non-combustible surface (not on linoleum or carpet)
- Due to the high temperature of the fireplace, it should be located out of traffic and away from furniture and draperies.
- This heater may be placed in a bedroom. Please be aware of the large amount of heat this appliance produces when determining a location.

Clearances

- When installed, walls in front of the fireplace must be a minimum 4-1/2" to the side of the faceplate.
- Fireplace must be placed so that no combustibles are within, or can swing within 36" of the front of the fireplace (e.g. drapes, doors)
- Fireplace must be placed so the vents below and above the glass do not become blocked

Corner Installations

A typical 45° installation uses the minimum framing dimensions shown in the illustration below (NOTE: all clearances still apply).

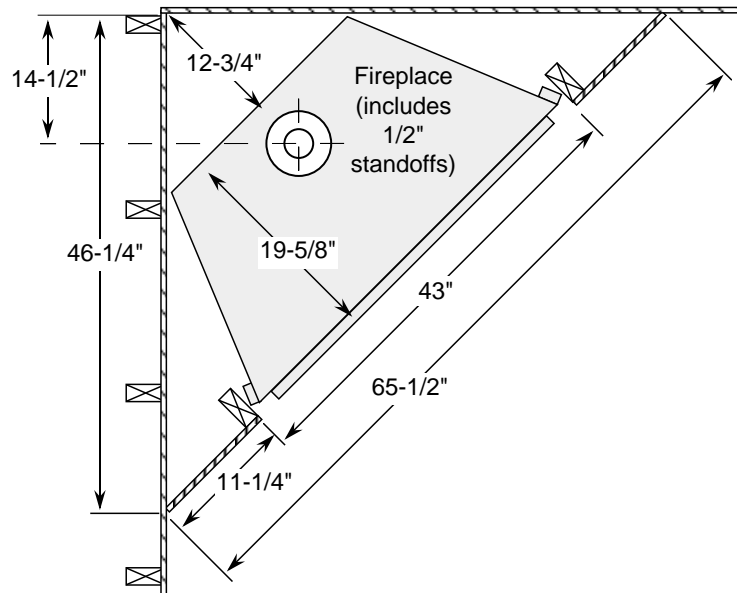

Raised Fireplaces

- The fireplace (and hearth, if desired) may be placed on a platform designed to support the fireplace (250 Lbs.) and vent.
- The fireplace may not be raised so as to place the ceiling within 24" of the top of the faceplate.

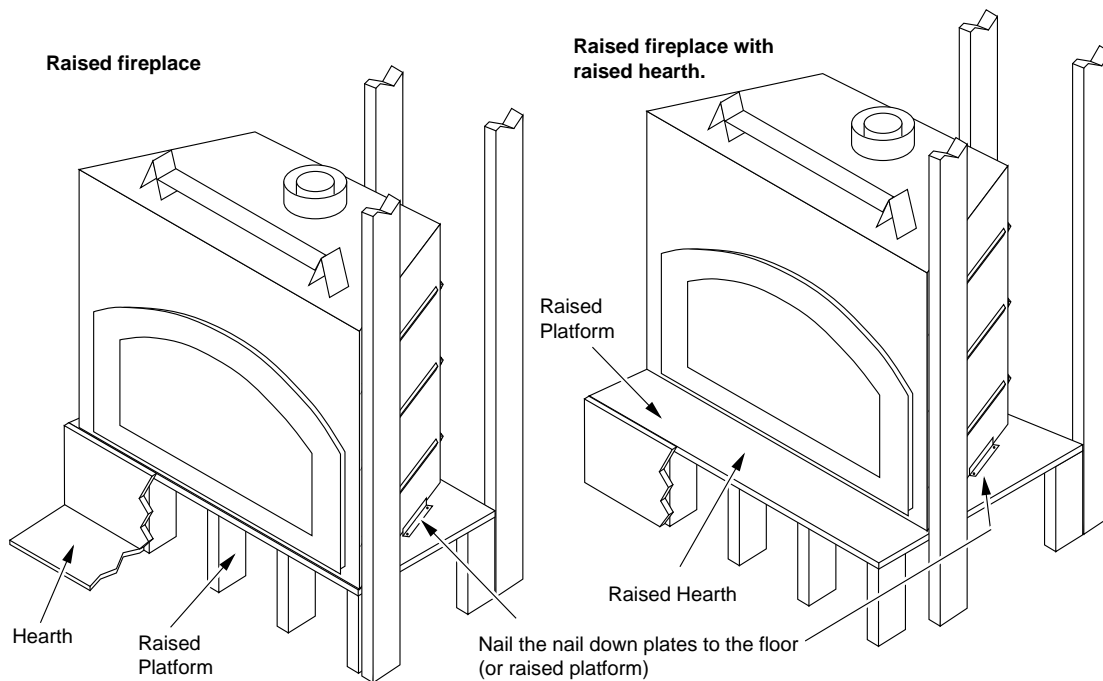

Hearth Requirements

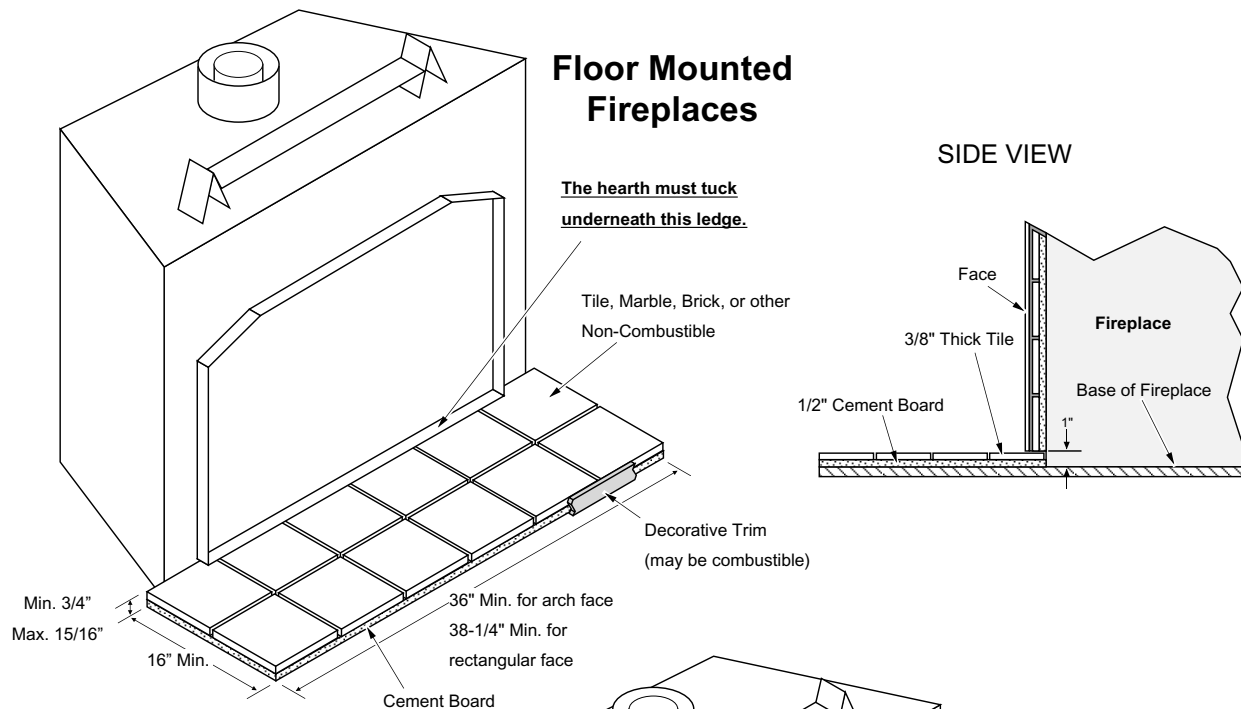

Hearth Requirement:

Min. 3/4" of non-combustible material (tile with cement board, marble, etc.)

Raised Fireplaces

When the base of the fireplace is raised a minimum of 3" off of the floor surface, no hearth is required.

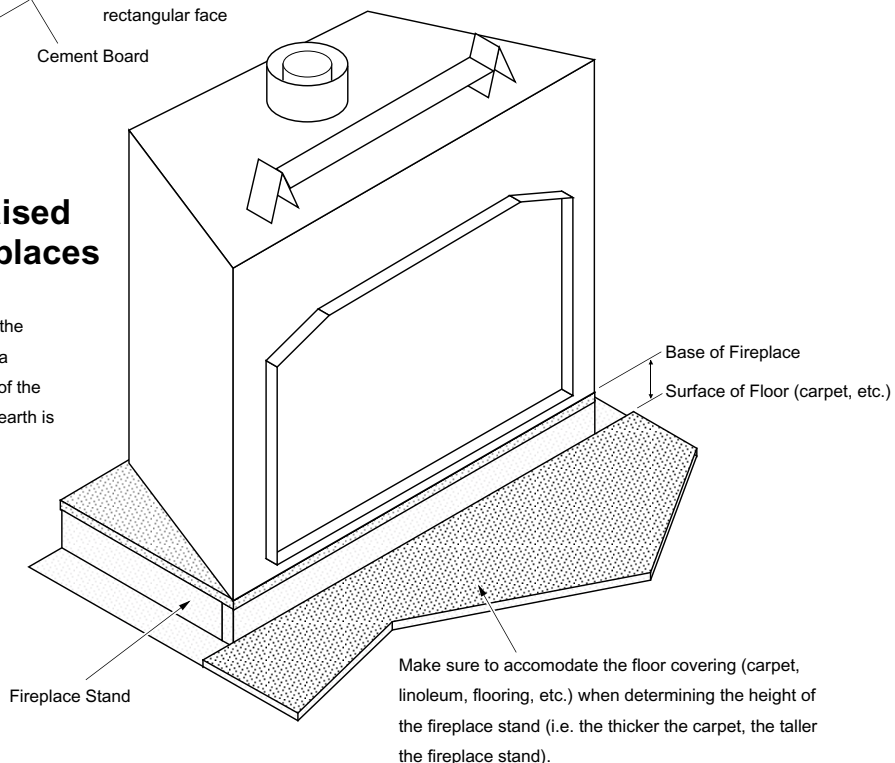

Facing Requirements

NOTE: The combustible area above the facing must not protrude more than 3/4" from the facing. If it does, it is considered a mantel and must meet the mantel requirements listed in this manual.



WARNING: Do not use adhesive to secure the cement board or facing. The high temperatures of the fireplace may cause adhesives to emit odors. Use mastic or thin set (or other non-combustible, non-odorous adherent) to attach the facing to the cement board.

NOTE: Screws may be used to secure the cement board to the fireplace. Do not penetrate the fireplace more than 3/4"

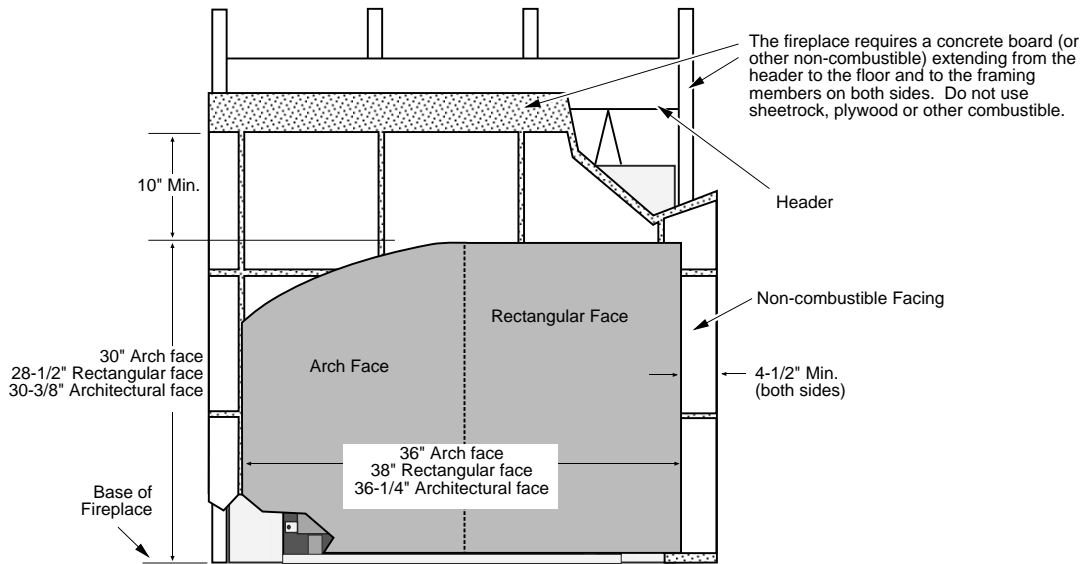

Facing Over 1" Thick

- Architectural faces require a 5/8" gap above the face for face installation.
- If the facing material is over 1" thick (e.g. brick, river rock), install the facing around the perimeter of the face. You may wish to make a face template (see the illustration to the right). If using an arch face, you may wish to order the optional set-up face:

Arch Set-Up Face

Part # 98500692

- For rectangular faces, use a piece of plywood cut to the dimensions shown on page 13 (add 1/8" to each dimension).
- Artisan faces vary in size. Use the face being installed to create a template.

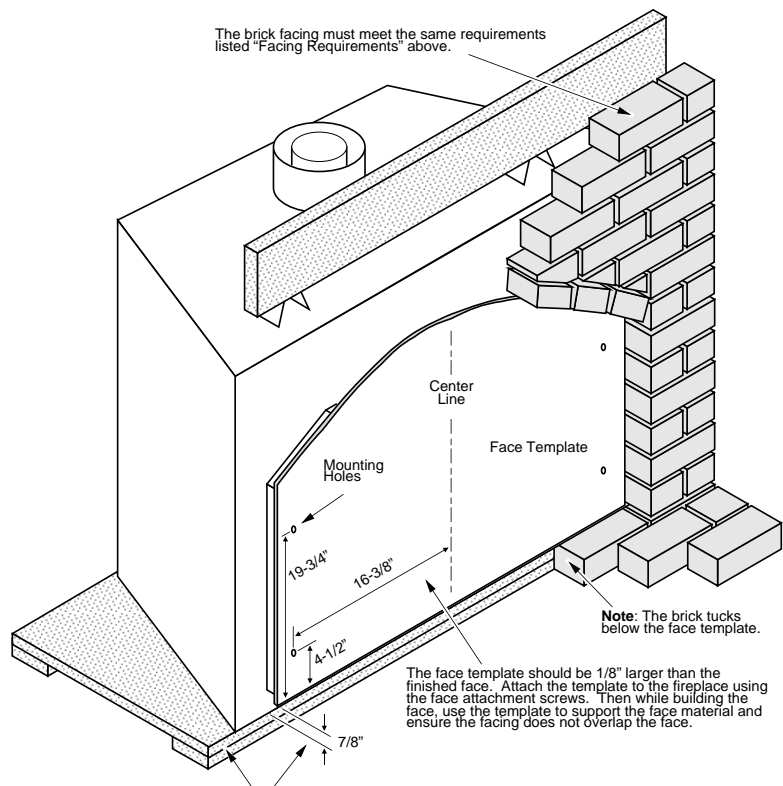

Note: if using a brick hearth, the fireplace will need to be raised to accommodate the 1" gap between the face and the base of the fireplace. For 2-1/2" thick brick this works out to approximately 1-5/8".

Facing Detail

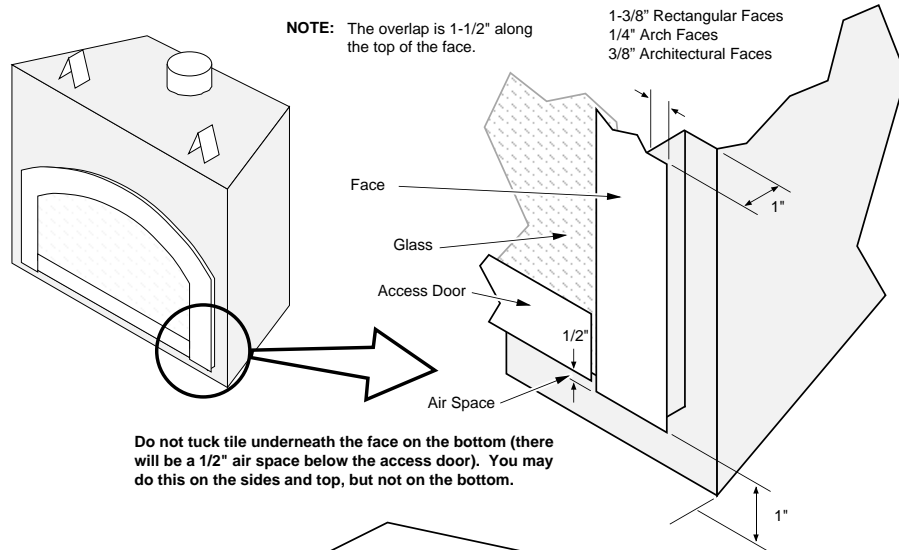

Do not tuck tile underneath the face on the bottom (there will be a 1/2" air space below the access door). You may do this on the sides and top, but not on the bottom.

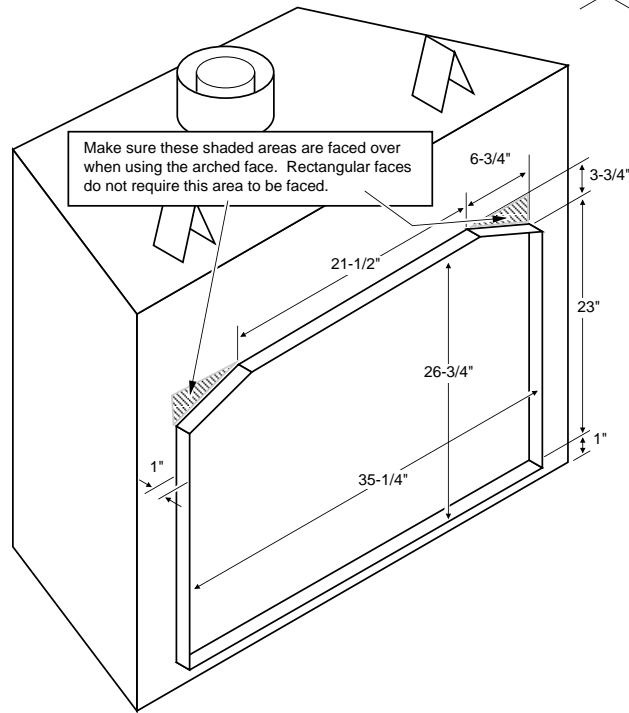

- To achieve a facing that is flush with the drywall to the side of the fireplace, recess the framing directly next to the fireplace. See the illustration below.

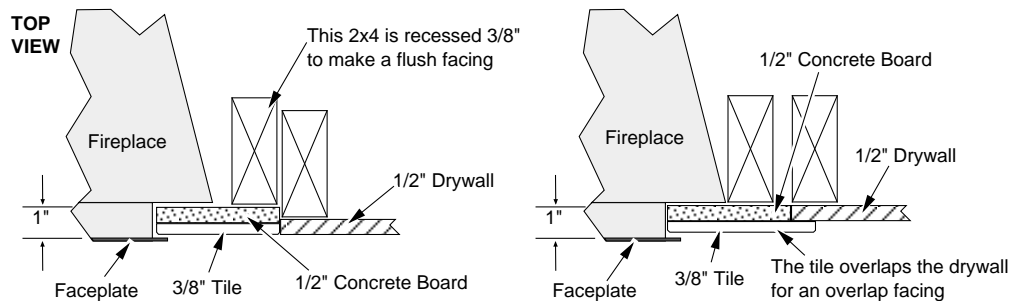

Face Dimensions

Classic Arched
(Gold, Black, or Artisan*)

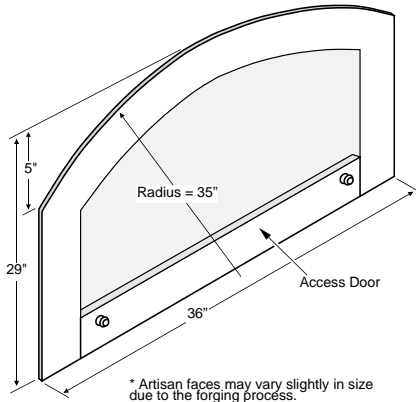

Rectangular Bevel Face
(Black or Gold)

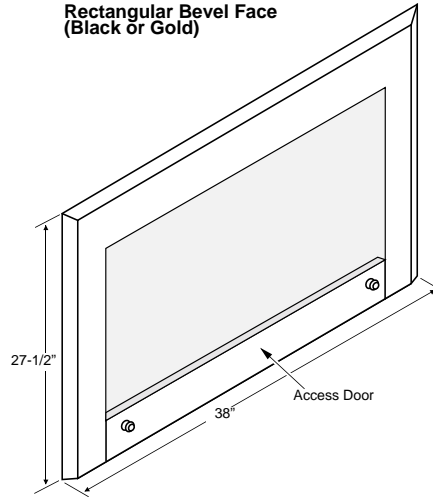

Architectural Faces
(French Country,
Arts & Crafts,
Art Deco, or Neo-Classical)

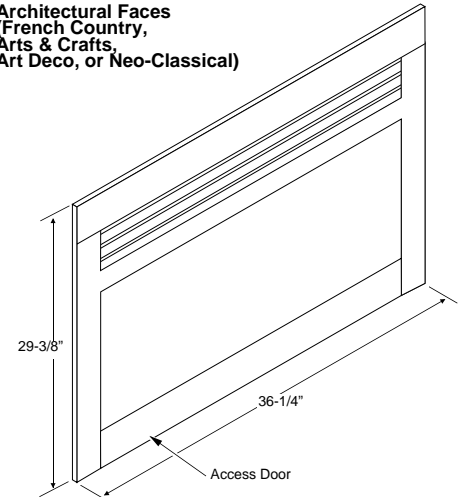

Modifying the Face Angle for Rectangular Faces

If using a rectangular face, adjust the face angles at the top corners of the glass (see the illustration below).

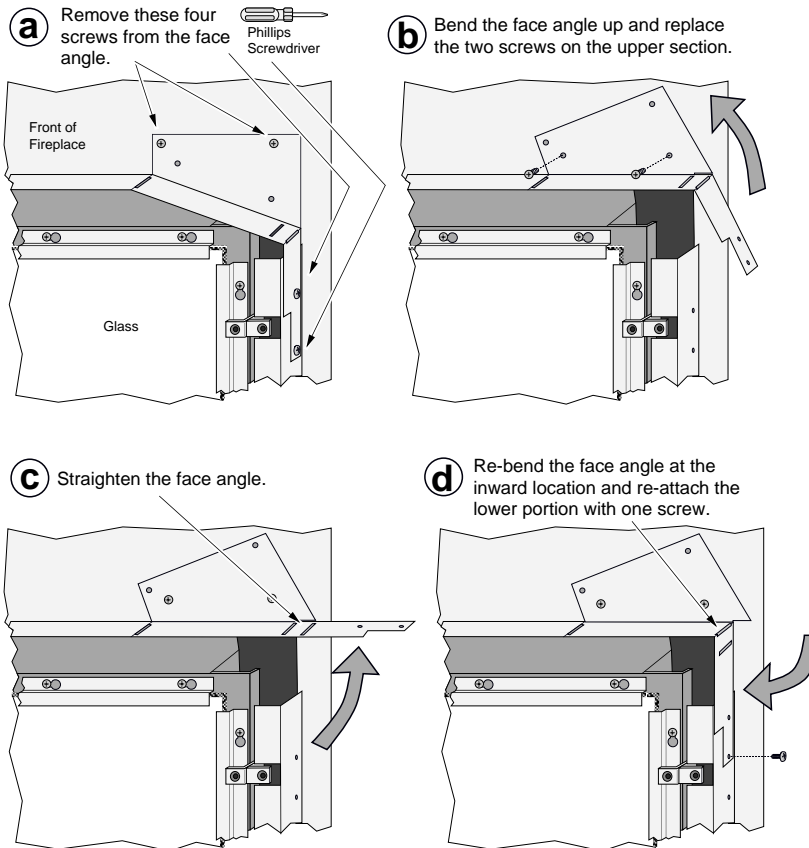

Facing and Hearth Examples

Side View

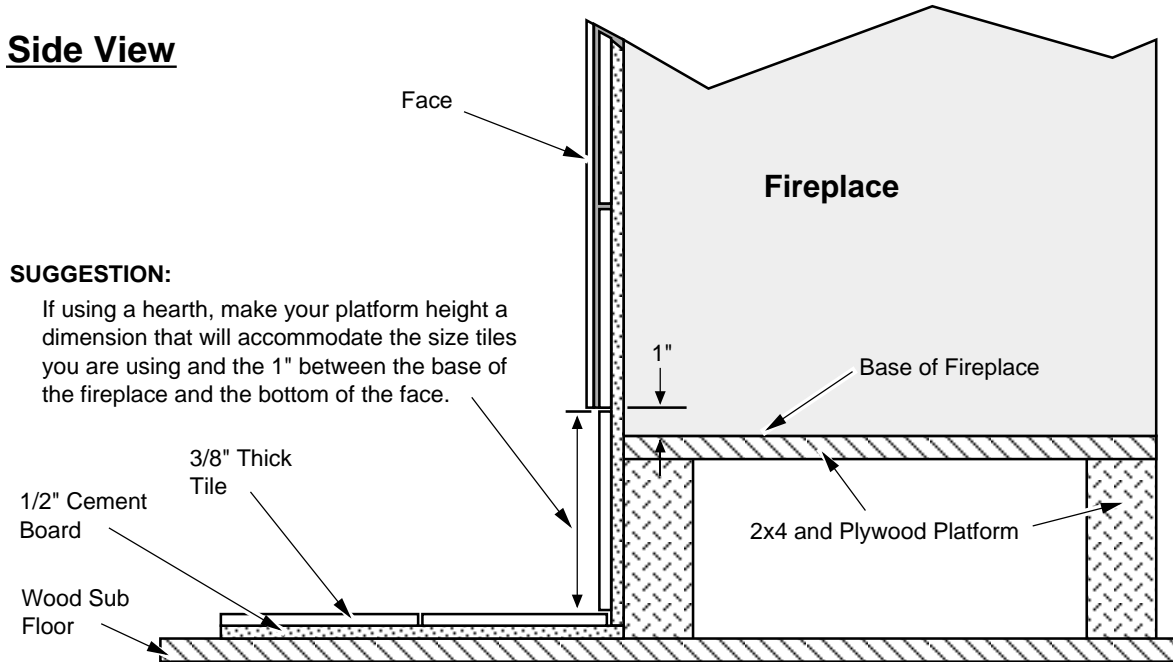

SUGGESTION:

If using a hearth, make your platform height a dimension that will accommodate the size tiles you are using and the 1" between the base of the fireplace and the bottom of the face.

Three-Dimensional View

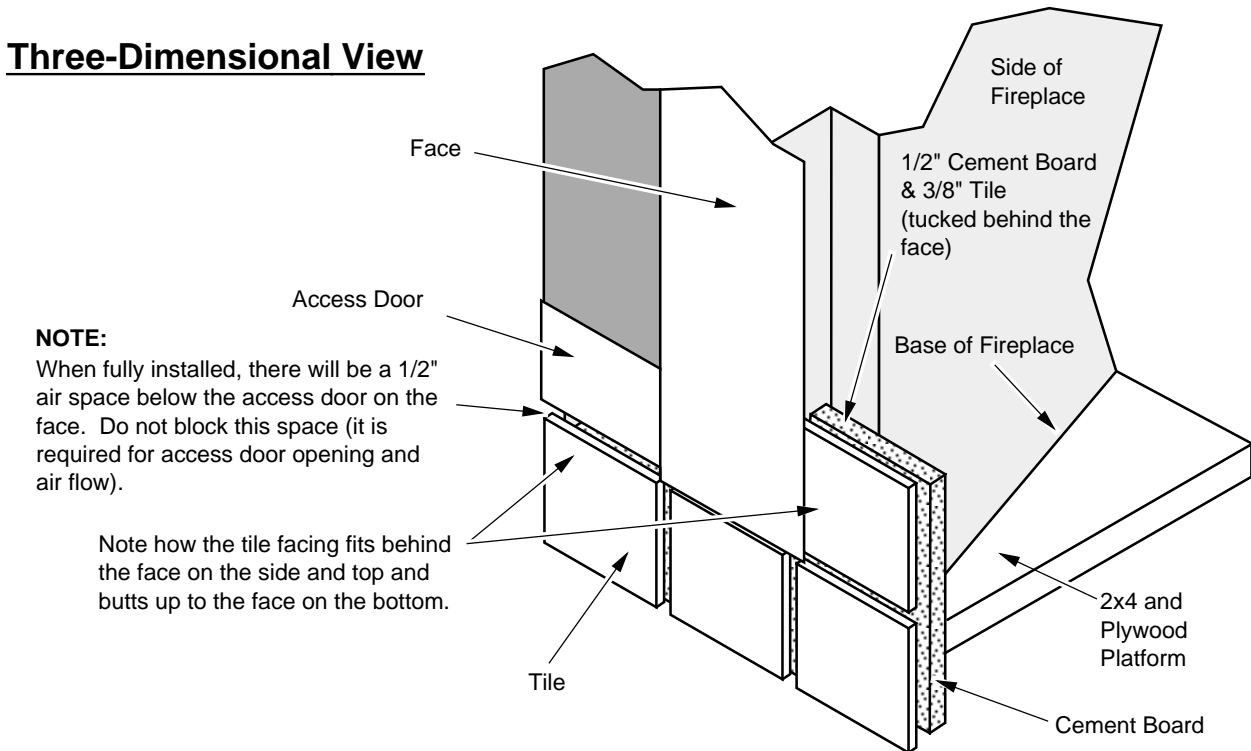

NOTE:

When fully installed, there will be a 1/2" air space below the access door on the face. Do not block this space (it is required for access door opening and air flow).

Note how the tile facing fits behind the face on the side and top and butts up to the face on the bottom.

Facing and Hearth Examples (continued)

Side View

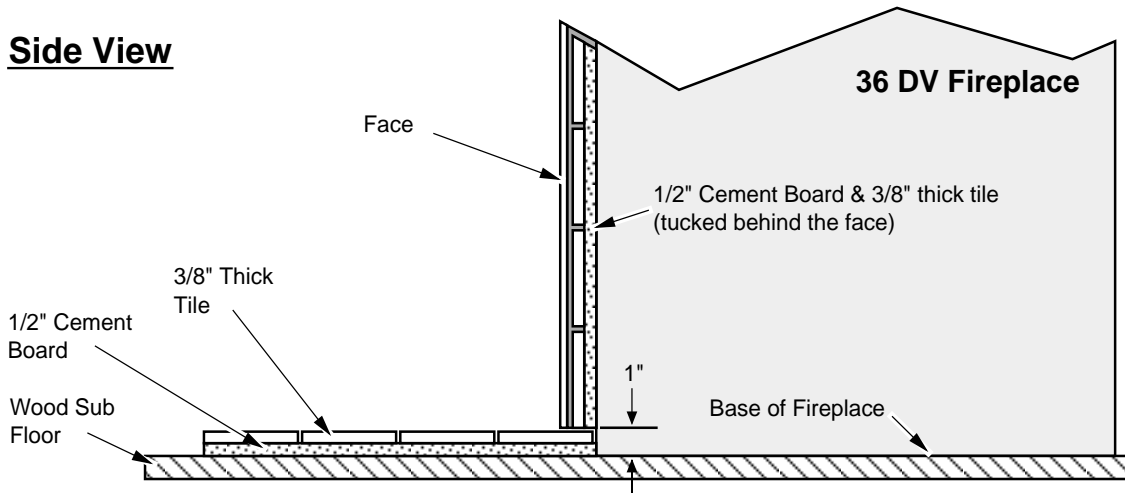

Three-Dimensional View

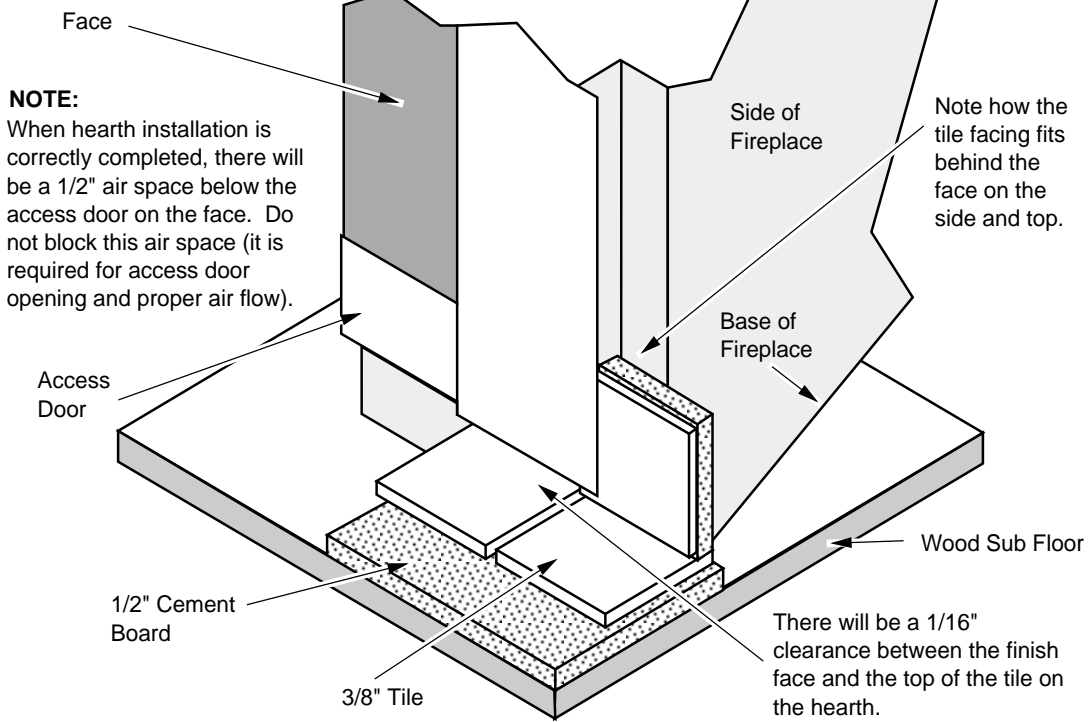

WARNING: Do not install cement board underneath the fireplace. To do so would leave a large gap underneath the finish faceplate sides.

Mantel Requirements

- The combustible area above the facing must not protrude more than 3/4" from the facing. If it does, it is considered a mantel and must meet the mantel requirements listed in this manual.

Combustible Mantels

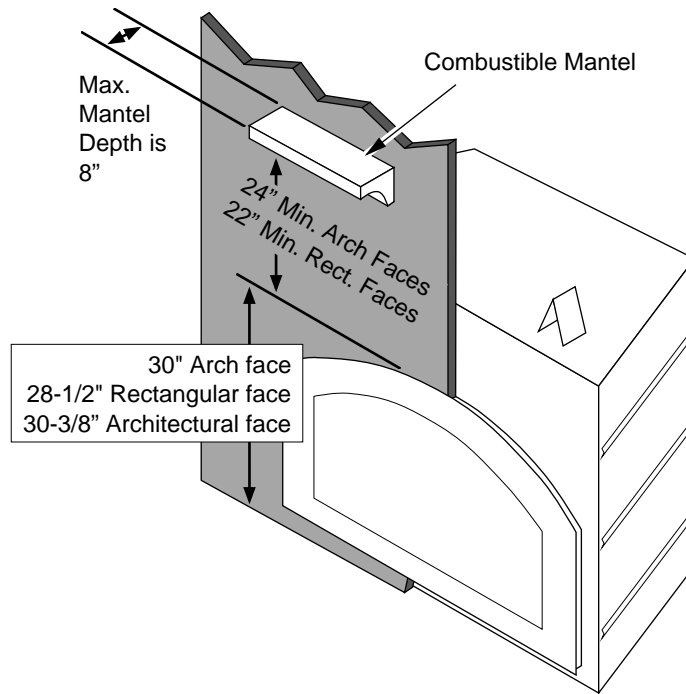

Non-Combustible Mantels

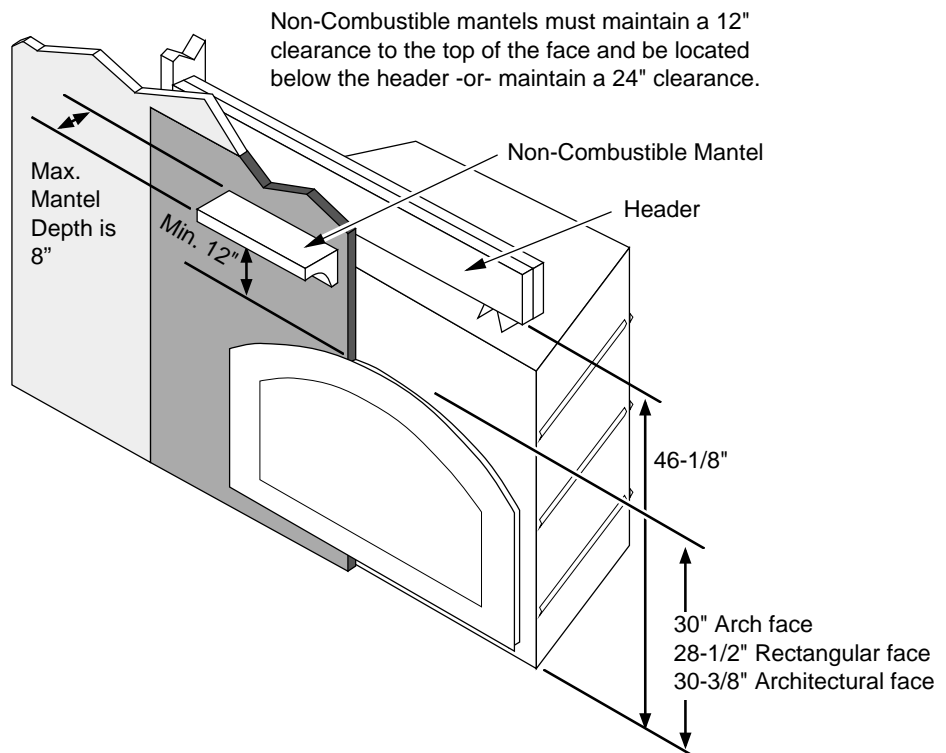

Vent Requirements

- ! The vent must maintain the required clearance to combustibles to prevent a fire (see "Clearances" below). Do not fill air spaces with insulation.
- ! The gas appliance and vent system must be vented directly to the outside of the building, and never be attached to a chimney serving a separate solid fuel or gas-burning appliance. Each direct vent gas appliance must use its own separate vent system.

Altitude Considerations

This heater has been tested at altitudes ranging from sea level to 8,000 feet (2,400 M). In this testing we have found that the heater, with its standard orifice, burns correctly with just an air shutter adjustment.

- ! Failure to adjust the air shutter properly may lead to improper combustion which can create a safety hazard. Consult your dealer or installer if you suspect an improperly adjusted air shutter.

Clearances

Minimum 1" clearance to all combustibles (measured from the outside of the pipe) **except** for the following:

When using 6-5/8" vent, a horizontal termination, and an elbow directly off the top of the fireplace, a 2" clearance is required above the horizontal sections (1" to the side and below).

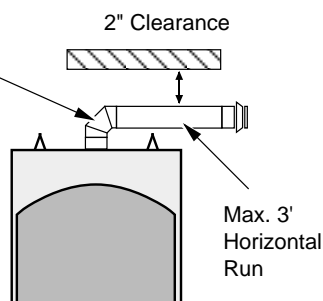

With any vertical vent directly off the fireplace, the clearance is 1".

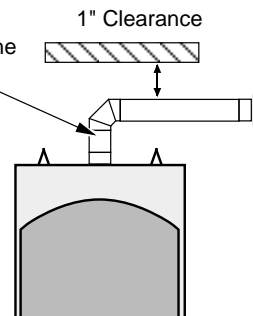

Use of 8" Diameter Pipe

- Most venting configurations use 6-5/8" diameter vent. To achieve longer horizontal runs (over 12') with a horizontal termination, 8" dia. Simpson DuraVent type GS Direct Vent may be used. See the section "Horizontal Terminations using 8" Diameter Vent" for details. Part Numbers are listed below.

Straight Lengths

1208B	6" Pipe Length, Black
1207B	9" Pipe Length, Black
1206B	12" Pipe Length, Black
1204B	24" Pipe Length, Black
1203B	36" Pipe Length, Black
1202B	48" Pipe Length, Black
1211B	11" to 14-5/8" Adjustable Pipe, Black

Terminations

1284	Horizontal Square Termination
1285	Hor. High Wind Termination
1250	Vinyl Siding Stand-off

Elbows

1245B	45° Elbow, Black
1290B	90° Elbow, Black

Penetration, Support

1242	Wall Firestop
1241	Cathedral Ceiling Support Box
1263	Ceiling Fire-stop
1288	Wall Strap

Adapter (6-5/8" to 8" dia.)

925T	DV GS 6-5/8" to 8" Increaser
------	------------------------------

Part Numbers for 6-5/8" Diameter Vent

- Use Model GS Direct Vent manufactured by Simpson Dura-Vent **only**. Follow the installation instructions included with the vent. For the nearest Simpson Dura-Vent supplier, call (800) 835-4429. Vent part numbers and descriptions are listed below.

Straight Lengths

908B	6" Pipe Length, Black (interior)
907B	9" Pipe Length, Black (interior)
906	12" Pipe Length, Galvanized
906B	12" Pipe Length, Black (interior)
904	24" Pipe Length, Galvanized
904B	24" Pipe Length, Black (interior)
903	36" Pipe Length, Galvanized
903B	36" Pipe Length, Black (interior)
902	48" Pipe Length, Galvanized
902B	48" Pipe Length, Black (interior)
911B	11" to 14 5/8" Adjustable, Black (interior)

Vent Terminations

981	Snorkel Termination (36" rise) (for basement or raised termination installations)
982	Snorkel Termination (14" rise) (for basement or raised termination installations)
984	Horizontal Square Termination
950	Vinyl Siding Stand-off
991	High Wind Vertical Termination

Elbows

990	90° Elbow
990B	90° Elbow, Black (interior)

Penetration, Support

942	Wall Thimble
941	Cathedral Ceiling Support Box
943	Flashing, 0/12 to 6/12 Roof Pitch
943S	Flashing, 7/12 to 12/12 Roof Pitch
953	Storm Collar
963	Ceiling Fire-stop
988	Wall Strap

Vent Installation

- In addition to the requirements below, follow the requirements provided with the vent.

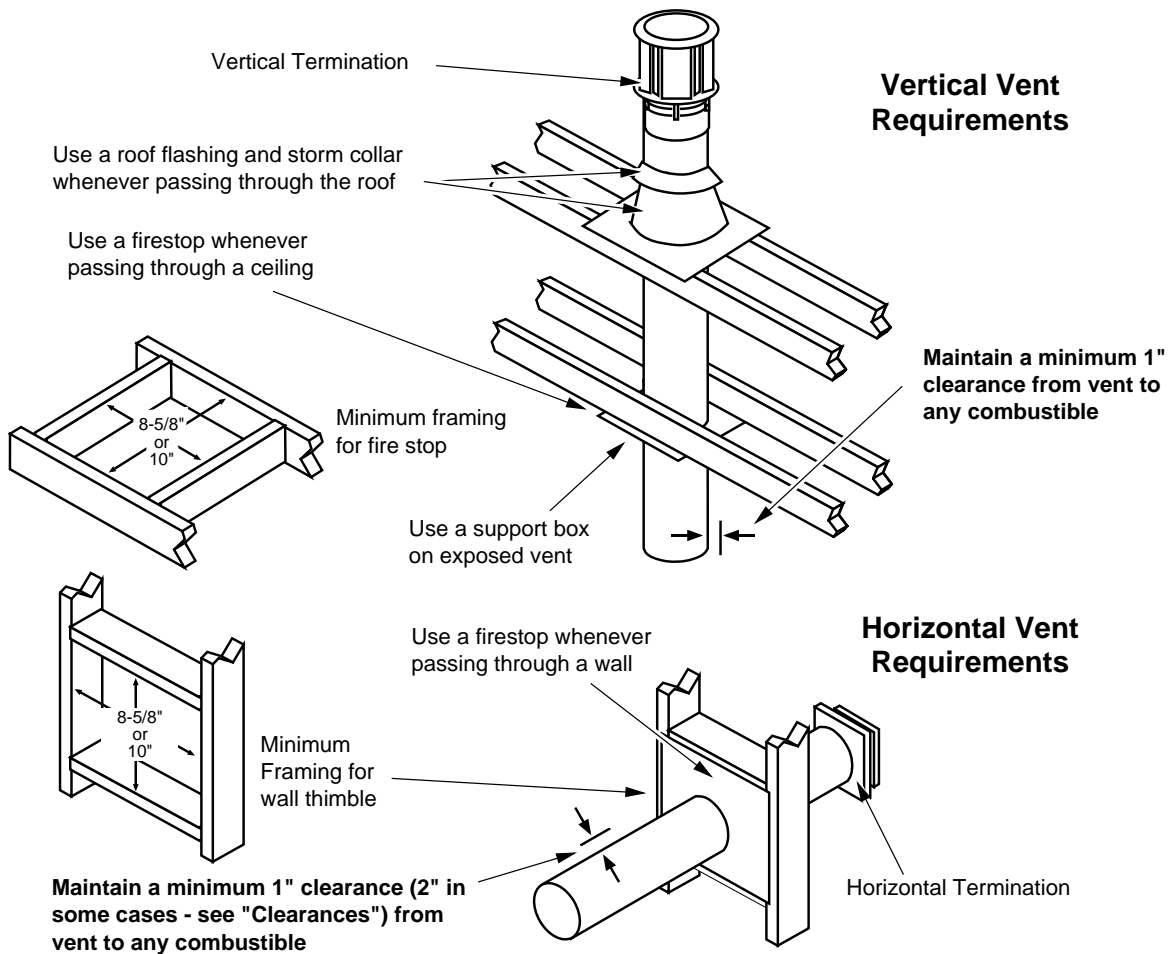

- Slide the vent sections together and turn 1/4 turn until the sections lock in place.
- Screws are not required to secure the vent. However, three screws may be used to secure vent sections together if desired.
- High temperature sealant is recommended at the appliance starter section connection (use high-temperature silicone or Mill-Pac®).
- If disassembly is required, at time of re-assembly check to see if the vent creates a tight fit. If it does not, apply high temperature sealant to the joints of the affected sections.
- Horizontal sections require a 1/4" rise every 12" of travel
- Horizontal sections require non-combustible support every three feet (e.g.: plumbing tape)

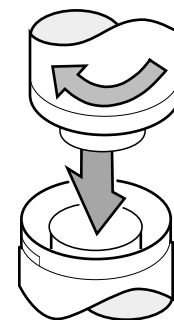

Approved Vent Configurations

Restrictor Position

- A vent restrictor is built into the appliance to adjust the flow rate of exhaust gases. This ensures proper combustion for all vent configurations. Depending upon the vent configuration, you may be required to adjust the restrictor position. The charts for acceptable vent configurations detail the correct vent restrictor position.

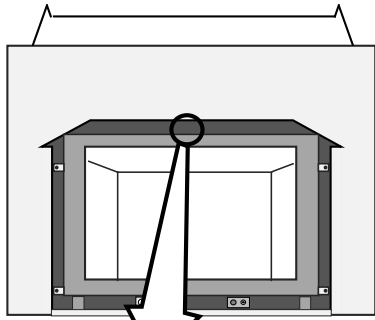

To Access the Restrictor:
With the face removed and the fireplace cool, reach above the firebox.

WARNING: Use a glove to protect your hand from burns.

To Adjust the Restrictor:

- Determine the correct restrictor position (see the charts under "Approved Vent Configurations" - the factory position is #1).
- Lift up the adjustment plate and move it so the correct notch falls into the slot on the adjustment bracket.

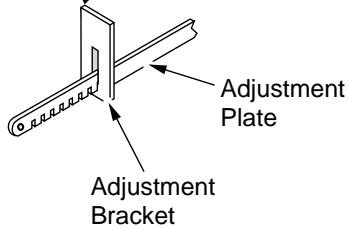

This restrictor is in position 1 (factory setting).

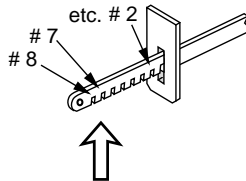

To adjust, lift up on the adjustment plate and push it back.

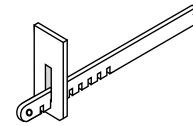

This restrictor is in position 7.

Elbows

- A maximum of three 90° elbows or four 45° offsets may be used. See the vent configurations for details.

NOTE: one 45° elbow may be used between two horizontal sections.

Elbows add 3" to the length of the vent system.

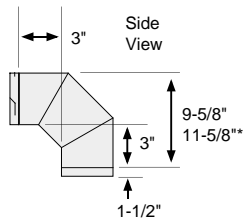

Vent sections overlap each other by 1-1/2"

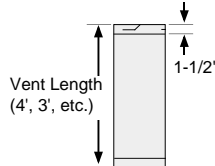

EXAMPLE:
Two 4' lengths are 7' 10-1/2" long, but when attached to the vent system add 7' 9" to the vent height.

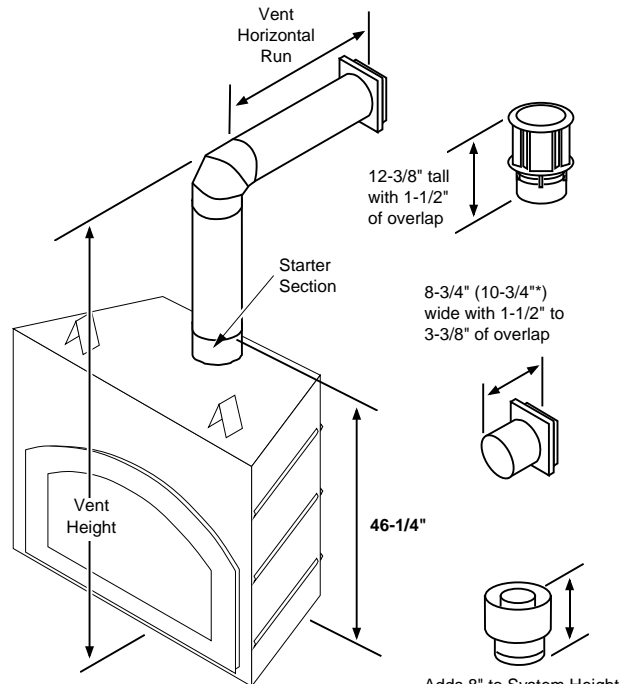

*** NOTE:**
All measurements are for 6-5/8" diameter vent except for those marked with an asterisk (*), which are for 8".

Vertical Terminations with 0, 2, or 4 45° Offsets using 6-5/8" Dia. Vent

- Use 6-5/8" diameter co-axial vent
- A Maximum of Four 45° Elbows May be Used
- 10' Minimum System Height (with or without offsets)
- 40' Maximum System Height
- 12' 8" Maximum Horizontal Offset

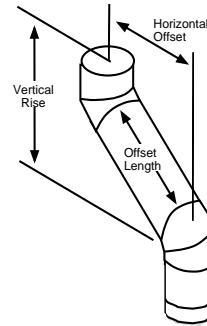

Offset Length	Hor. Offset	Vert. Rise
None	5"	1'
1' Section	1'	1' 7"
2' Section	1' 9"	2' 4"
3' Section	2' 5"	3'
4' Section	3' 2"	3' 8"

- The termination must fall within the shaded area shown in the chart. Use the indicated restrictor position.

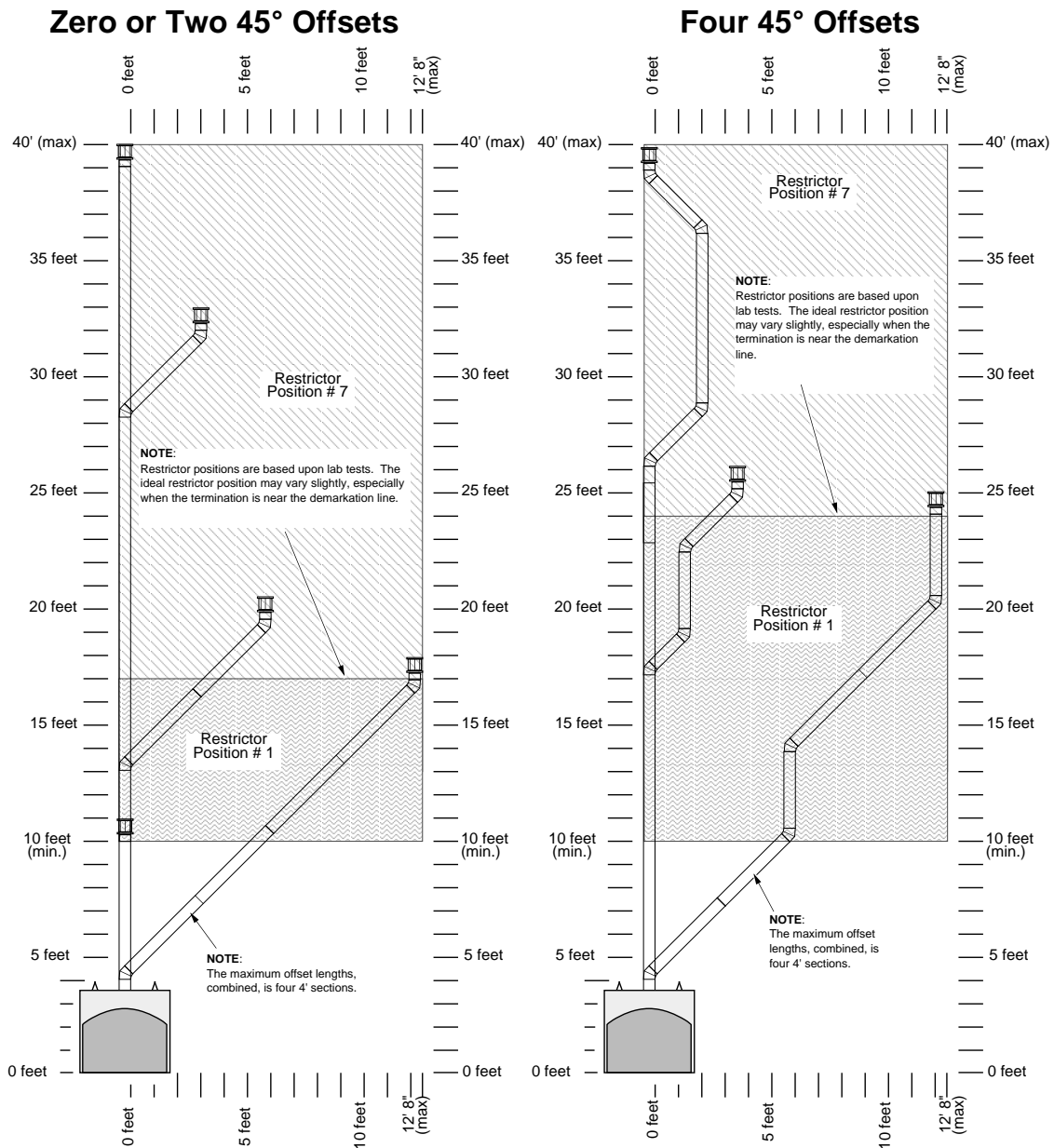

Horizontal Terminations using 6-5/8" Diameter Vent

Use a single 90° elbow (NOTE: an additional 45° elbow may be used on the horizontal run).

The termination must fall within the shaded area shown in the chart. Use the indicated restrictor position.

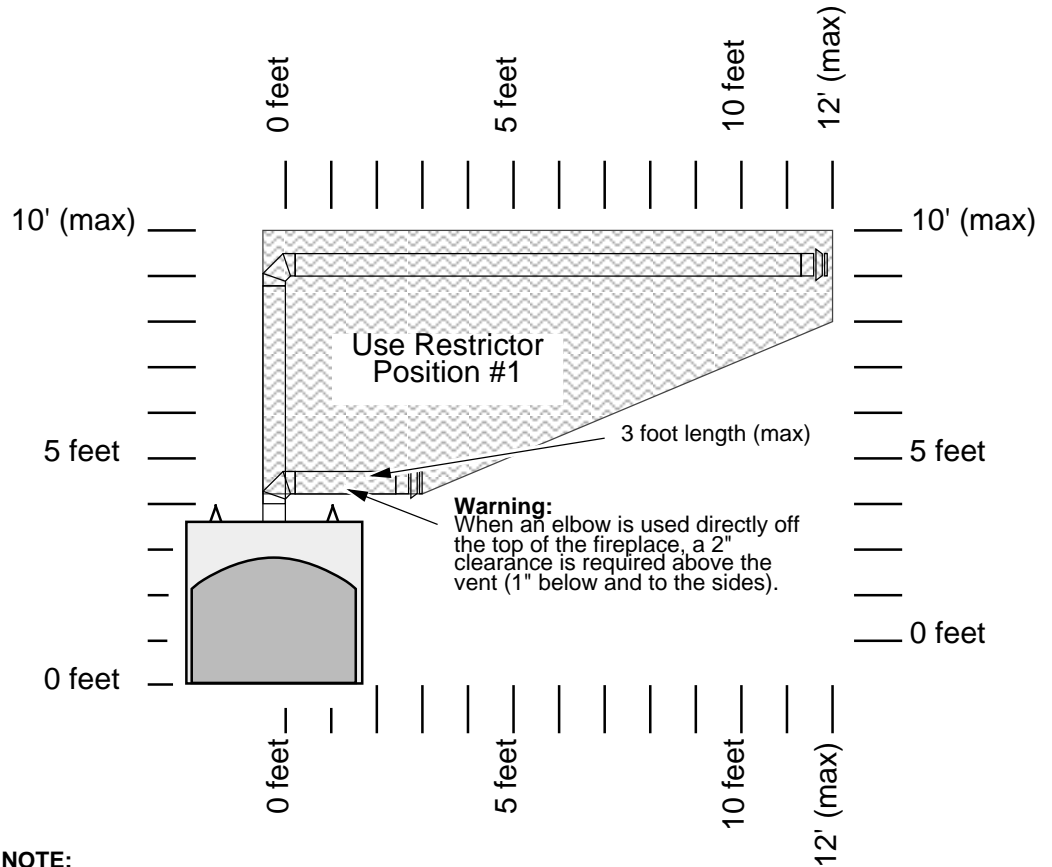

NOTE:

- Horizontal sections require a 1/4" rise every 12" of travel.
- Restrictor positions are based upon lab tests. The ideal restrictor position may vary slightly.

Vertical Terminations with Two or Three 90° Elbows Using 6-5/8" Dia. Vent

The termination must fall within the shaded area shown in the chart. Use the indicated restrictor position.

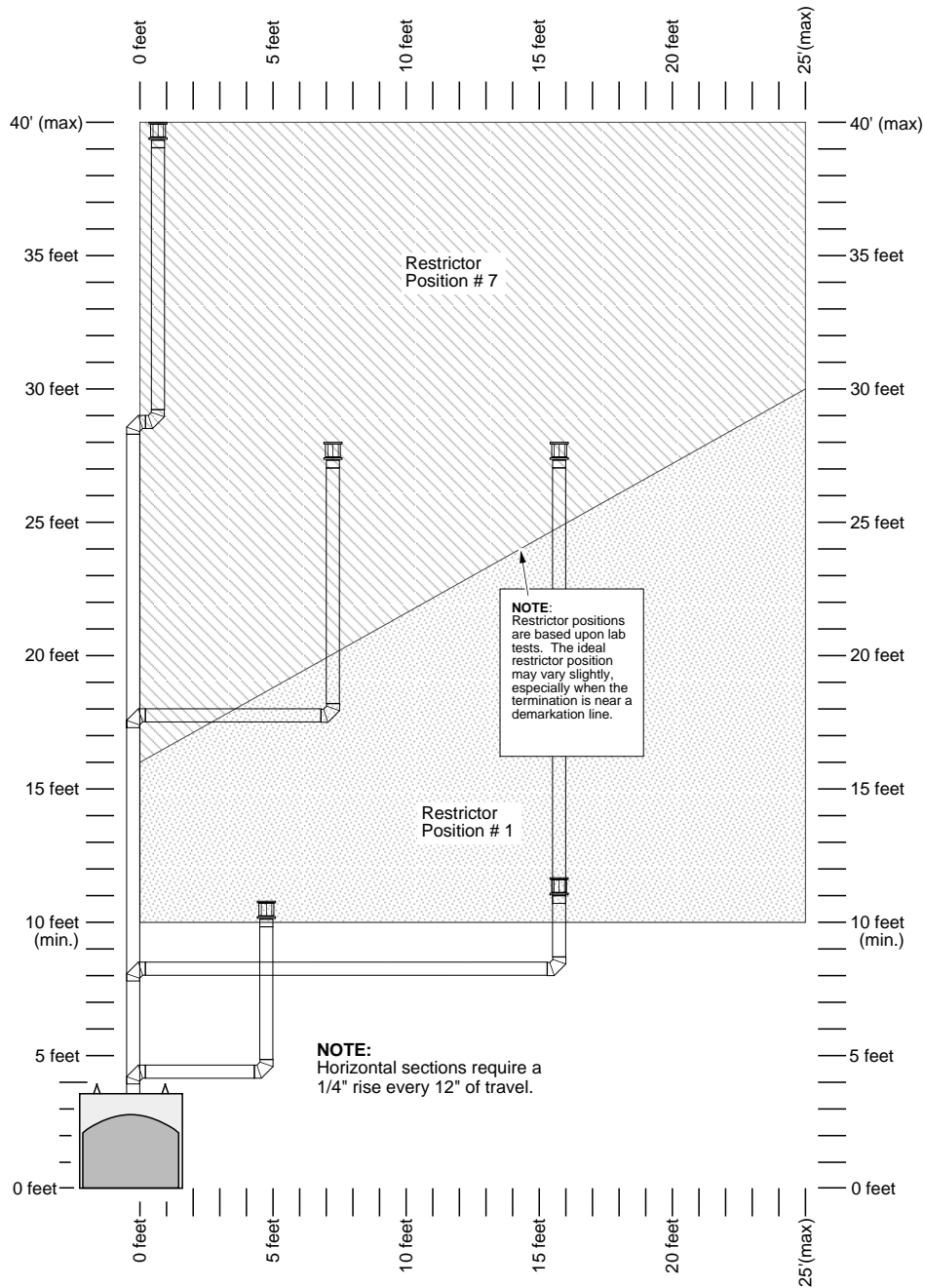

NOTE:

- Horizontal sections require a 1/4" rise every 12" of travel.
- The maximum vertical height is 40'.
- The maximum horizontal length is 25'.
- One horizontal elbow is allowed. The horizontal vent length is calculated by adding the length before and after the elbow ($H1 + H2 = \text{horizontal vent length}$).

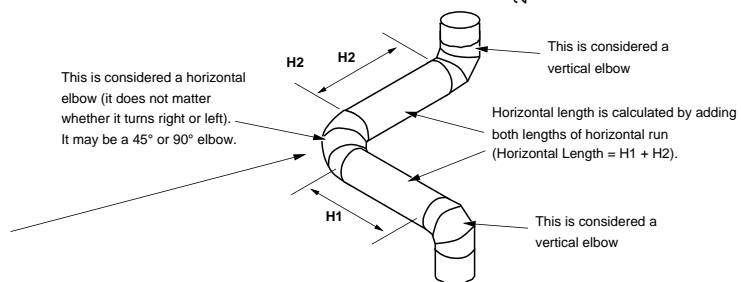

Horizontal Terminations using 8" Diameter Vent

The termination must fall within the shaded area shown in the chart. Use the indicated restrictor position.

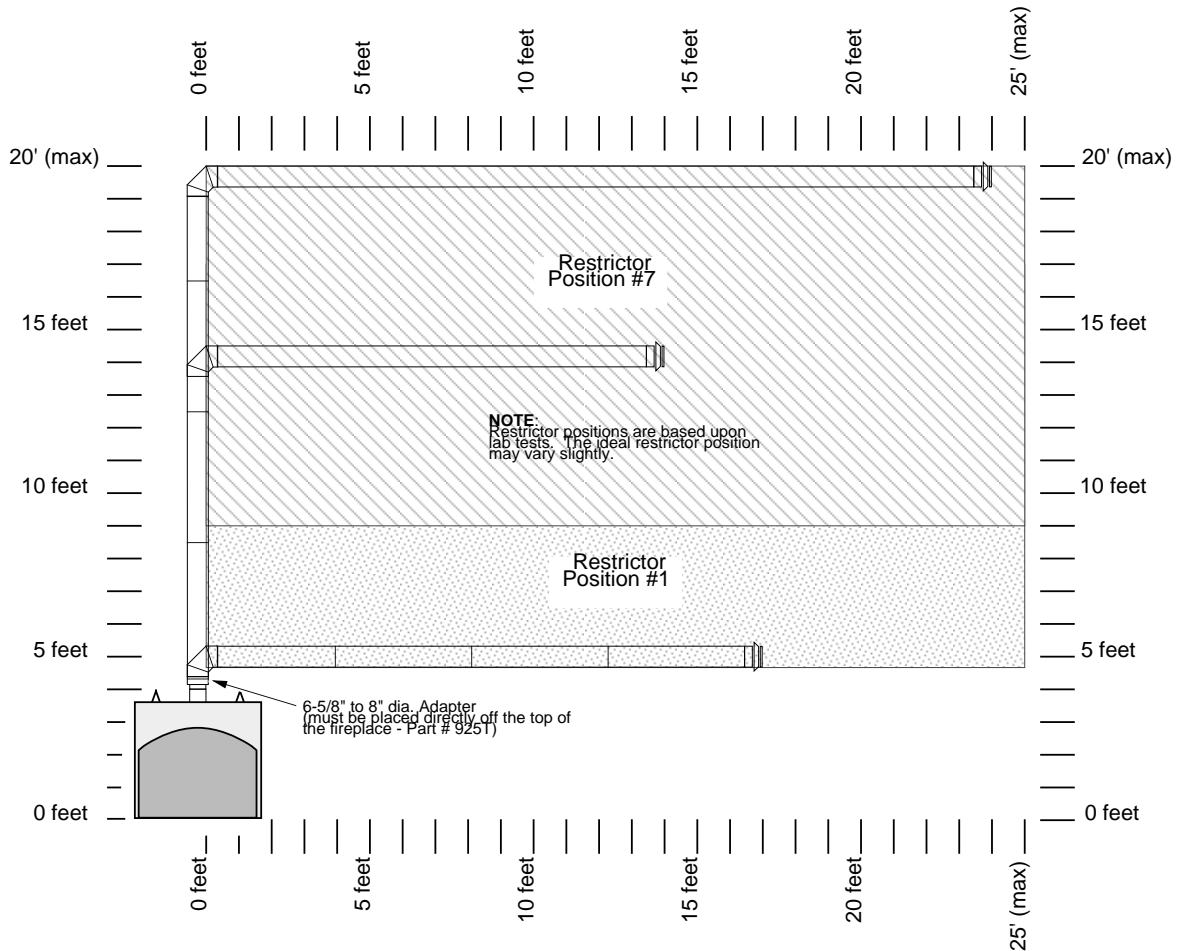

NOTE:

- Horizontal sections require a 1/4" rise every 12" of travel.
- The maximum vertical height is 20'.
- The maximum horizontal length is 25'.
- One horizontal elbow (45° or 90°) is allowed when using 8" vent. The horizontal vent length is calculated by adding the length before and after the elbow ($H1 + H2 = \text{horizontal vent length}$).

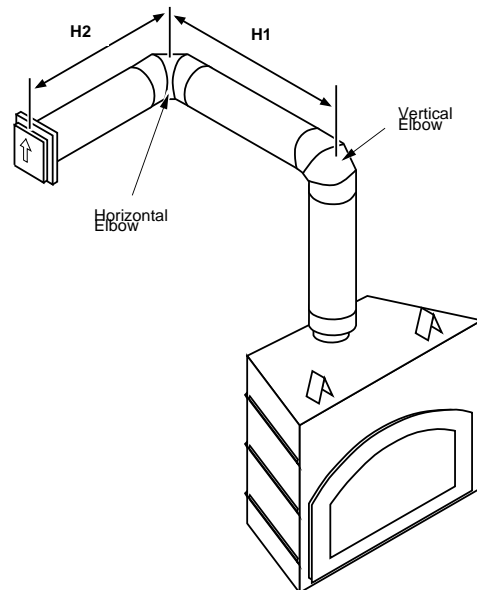

Termination Requirements (see the illustration below)

- A Minimum 9" clearance from any door or window
- B Minimum 12" above any grade, veranda, porch, deck or balcony
- C Minimum 12" from outside corner walls
- D Minimum 12" from inside corner walls
- E Minimum 11" clearance below unventilated soffits or roof surfaces
Minimum 18" clearance below ventilated soffits
Minimum 6" clearance from roof eaves
- NOTE:** Vinyl surfaces require 24"
- F Minimum 18" clearance below a veranda, porch, deck or balcony (must have two open sides)
- G Minimum 48" clearance from any adjacent building
- H Minimum 84" clearance above any grade when adjacent to public walkways or driveways
NOTE: may not be used over a walkway or driveway shared by an adjacent building
- I Minimum 48" clearance from any mechanical air supply inlet, 72" for Canada
- J Minimum 36" clearance above and 48" below and to the sides of non-mechanical air supply inlet
- K Minimum 36" from the area above the meter/regulator (vent outlet)
- L Minimum 36" from the meter/regulator (vent outlet)
- M Minimum 12" above the roof line (for vertical terminations)
- *Note:** In Canada the vent termination must be a minimum 2' (.6 M) tall and 2' (.6 M) above any portion of the roof within 10' (3 M) of the vent.
- N Minimum 24" horizontal clearance to any surface (such as an exterior wall) – for vertical terminations

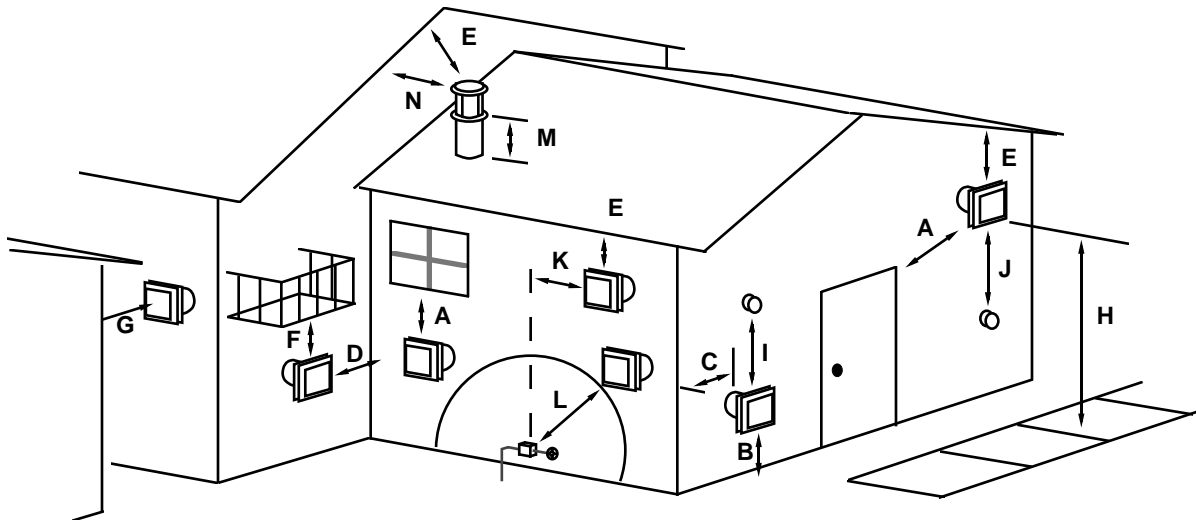
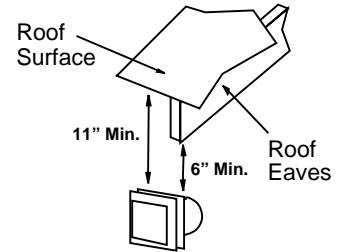

NOTE: Measure clearances to the nearest edge of the exhaust hood.

- Use the vinyl siding standoff (#950) when installing on an exterior with vinyl siding.
- Vent termination must not be located where it will become plugged by snow or other material
- These clearances meet UMC-1994 and the CNA/CGA-B149 code standards.

Gas Line Requirements

- ! The gas line must be installed in accordance with all local codes, if any; if not, follow ANSI 223.1 and the requirements listed below.
- ! The fireplace and gas control valve must be disconnected from the gas supply piping during any pressure testing of that system at test pressures in excess of 1/2 psig. For pressures under 1/2 psig, isolate the gas supply piping by closing the manual shutoff valve.
- ! Leak test all gas line joints and the gas control valve prior to and after starting the fireplace.

Fuel

- This fireplace is designed either for natural gas or for propane (but not for both). Check the sticker on the top of the gas control valve to make sure the correct fuel is used.

Gas Line Connection

- A manual shutoff valve is required for installation (within 3' of the heater or inside the fireplace). T-Handle gas cocks are required in Massachusetts in compliance with code 248CMR.
- Installation must be performed by a qualified installer, service agency or the gas supplier (In Massachusetts a licensed plumber/gasfitter).

The 1" diameter access hole is located 1-7/8" above the base of the fireplace. Cut an "X" in the gasket covering the inlet and insert the gas line through the gasket.

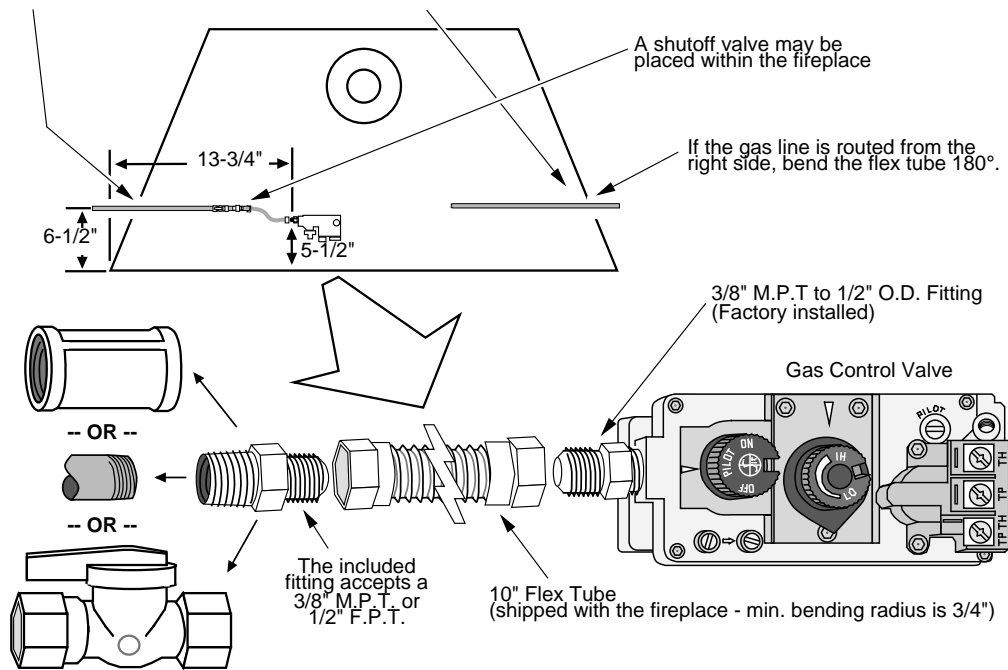

Gas Inlet Pressure:

	Standard Input Pressure
Natural Gas	7" W.C. (1.74 kPa)
Propane	13" W.C. (2.73 kPa)

- If the pressure is not sufficient, make sure the piping used is large enough, the supply regulator is adequately adjusted, and the total gas load for the residence does not exceed the amount supplied.
- The supply regulator (the regulator that attaches directly to the residence inlet or to the propane tank) should supply gas at the suggested input pressure listed above. Contact the local gas supplier if the regulator is at an improper pressure.

Electrical Connection

- ! Make sure the household breaker is shut off prior to working on any electrical lines.
 - ! The fireplace must be properly grounded in accordance with local codes (or ANSI/NFPA 70-1987)
 - The electrical line must be 14 gauge, and supply 120 Volts at 60 Hz (2 Amps)
- 1 Follow the directions below to connect power to the fireplace.

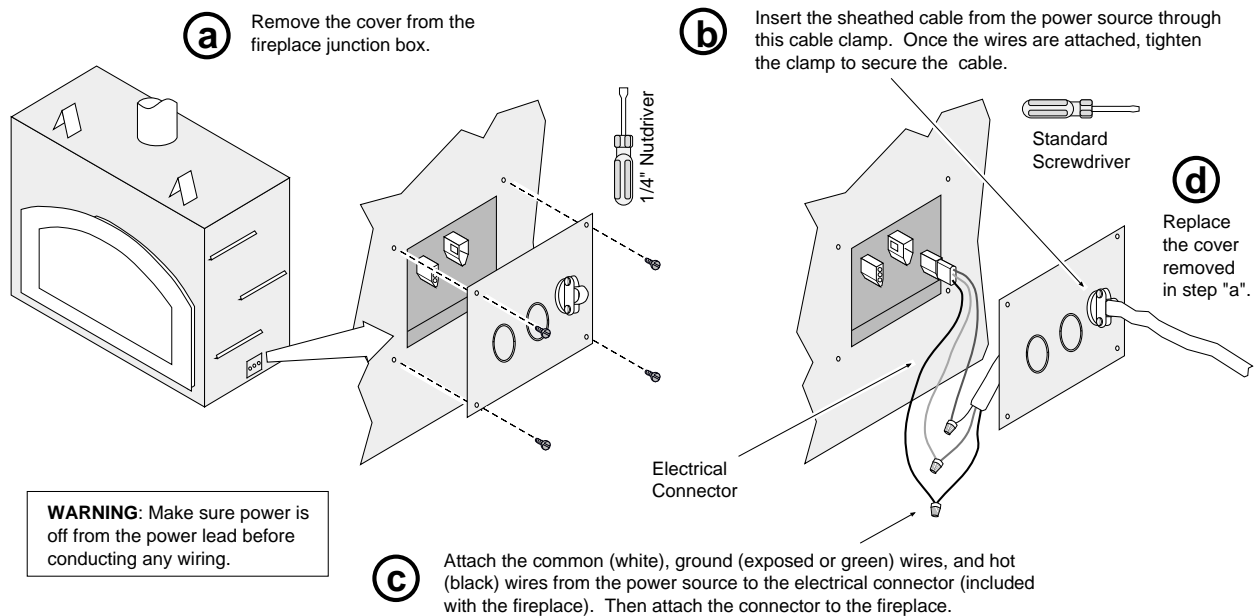

1 Remove the glass frame (and arch covers) following the directions below.

Warning: The appliance must be completely cool before removing the glass.

Note: If using an arch face, attach the arch covers after re-installing the glass.

a Open the four latches holding the glass frame in place (start with the bottom two) - follow the directions shown to the right.

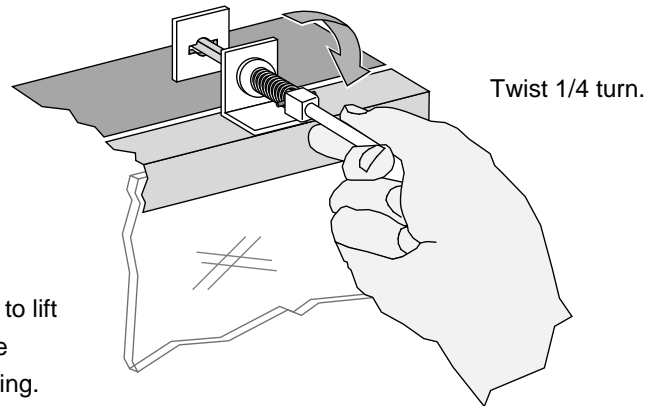
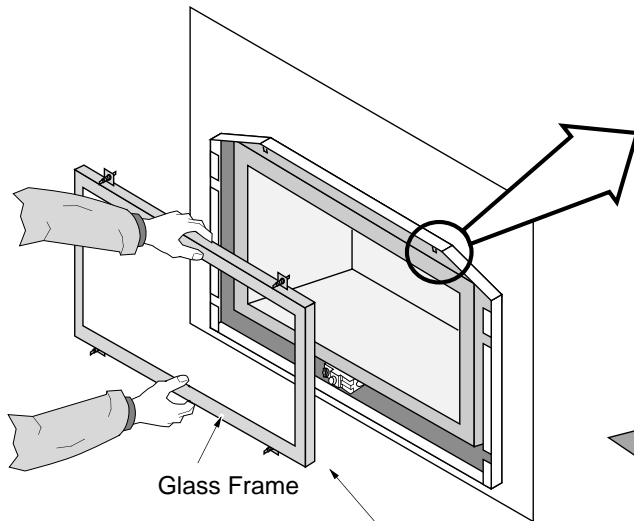
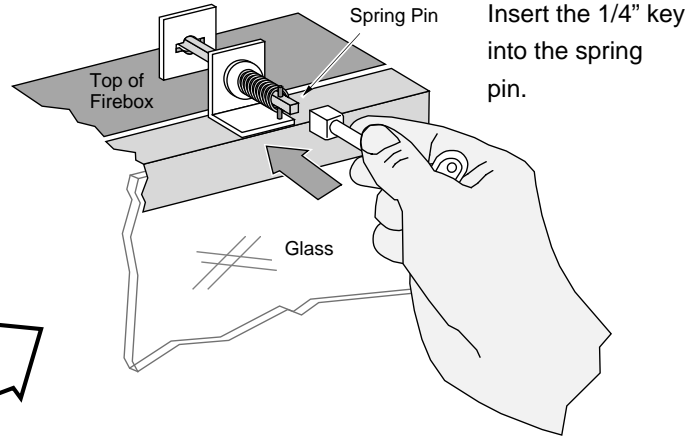

b Lift the glass frame up and pull it forward to remove.

NOTE: You may need to lift the glass frame while re-attaching.

Re-Attaching the Glass Frame:

- a) Hang the glass frame on the firebox.
- b) While holding in place, attach the upper latches (follow the instructions to the right in reverse).
- c) Lift the glass frame slightly and attach the lower latches.

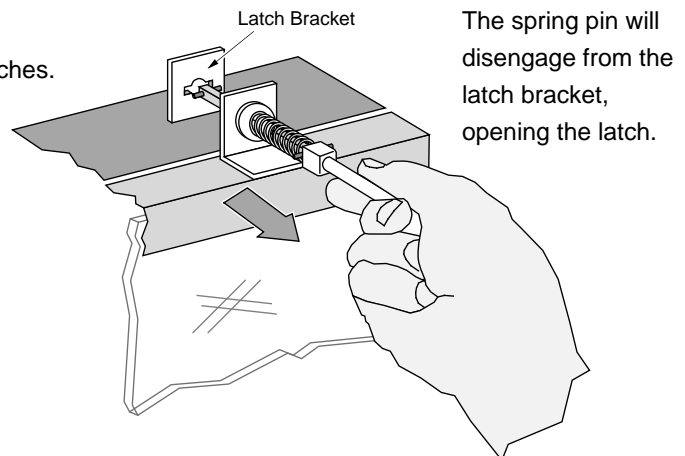

Arch Covers (both sides)

The arch covers (included in the owner's pack) block light from exiting the scroll work on arched faces. The covers hang on the glass frame.

Arch Faces: Attach arch covers before installing the face.

Rectangular Faces: Discard the arch covers.

Glass Frame Removal (continued) - Spring Pin Installation

The spring pin can come loose from the latch assembly. This occurs when it is turned 1/4 turn when it is disengaged. Follow the directions below to re-install the spring pin if it becomes loose.

NOTE: The spring pins can be installed with the glass frame in place or removed.

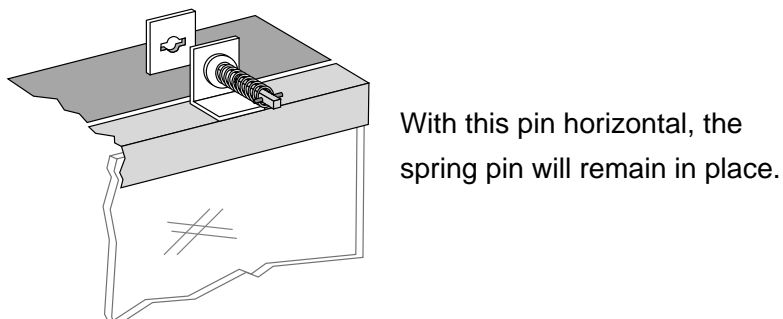
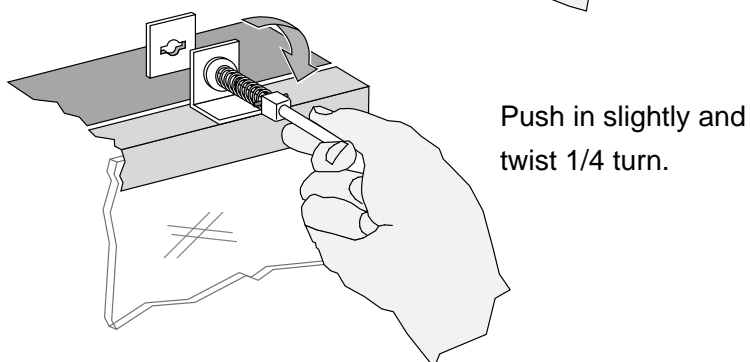
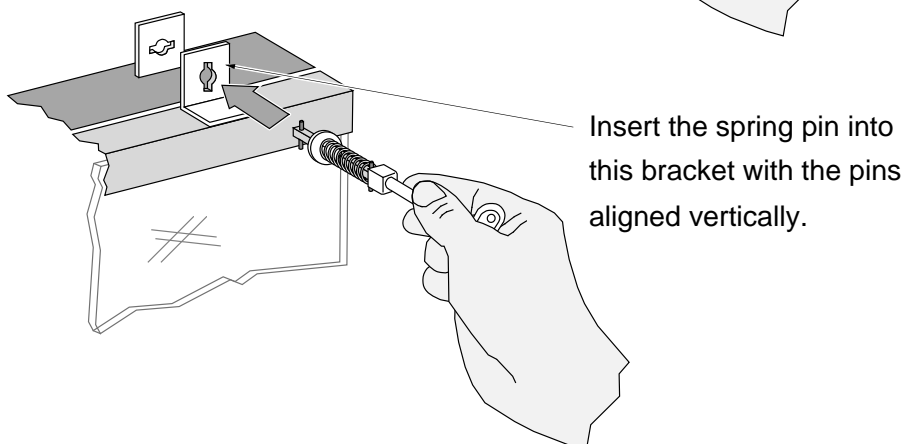
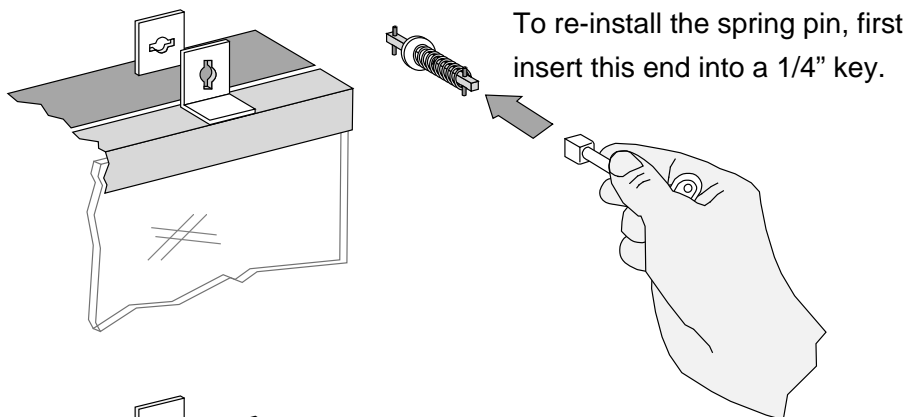

- ? If converting to propane or using the firebacks, do so now before installing the logs (page 43 and 54).
- 2 Install the log set following the directions below.

Step 1 Install the logs (see the illustration below).

Place the rear log on the two platforms at the rear of the firebox.

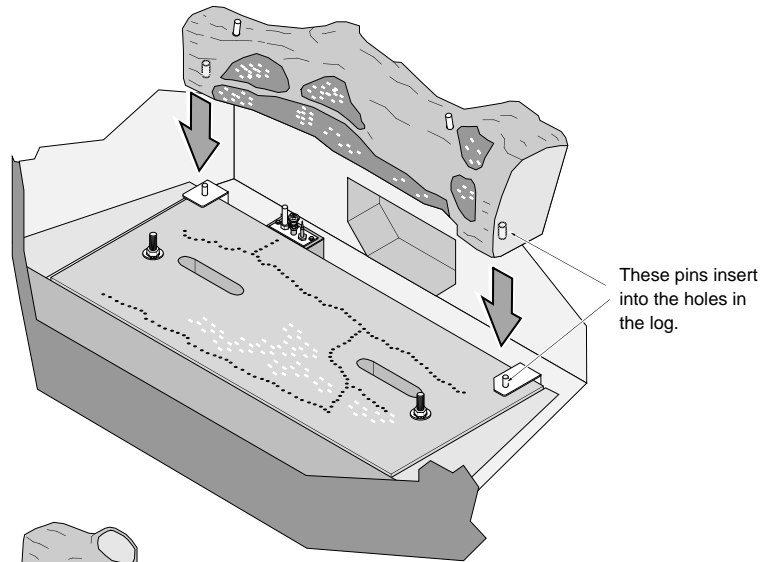

Place the front logs on top of the burner.

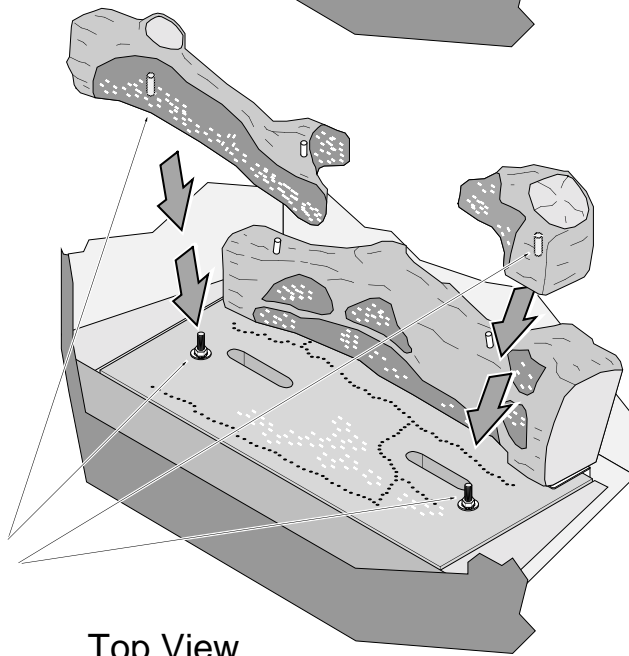

These bolts insert into the holes in the logs.

Top View

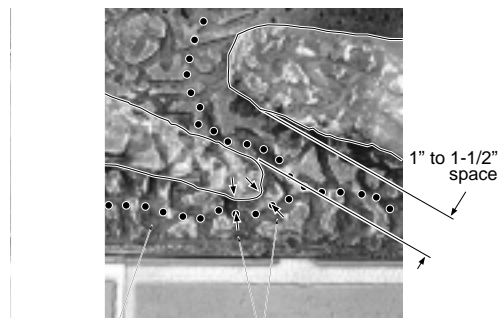

Do not place logs over burner holes.

Note how the front left log is spaced 1/4" to 3/8" off of the burner holes.

Step 2 Install the twigs and ember chunk (see the illustration below).

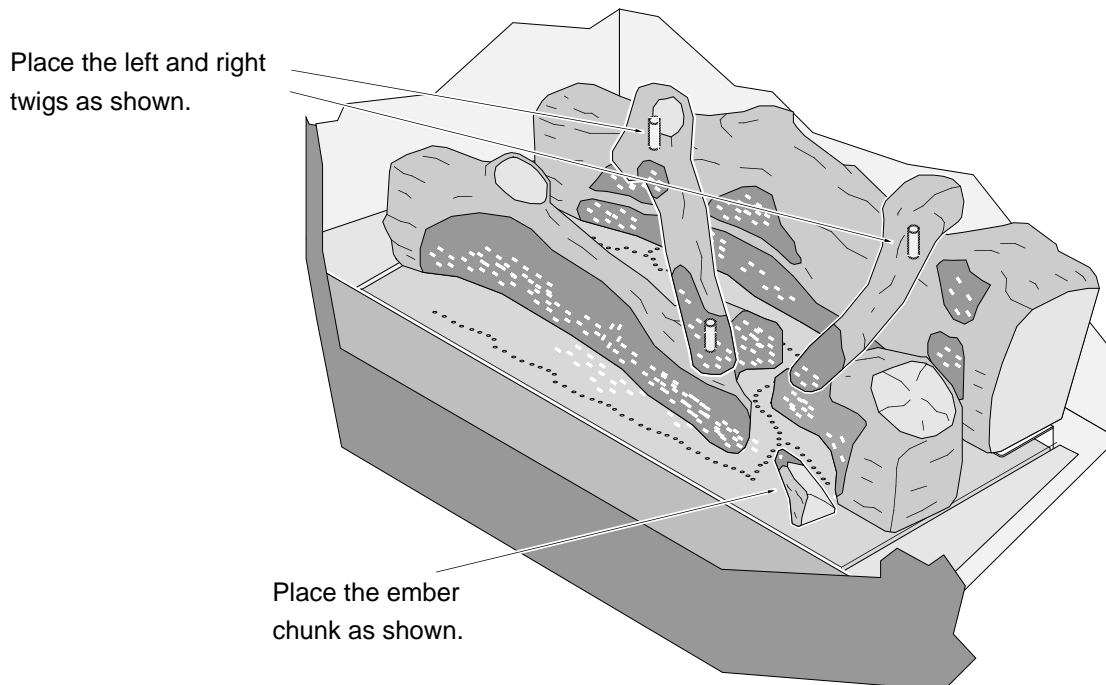

Step 3 Install the embers along the front of the burner (see the illustrations below). Do not place the embers over the burner holes.

Front View



Side View



! We recommend you purge the gas line at this time (with the glass removed). This allows gas to be detected once it enters the firebox, ensuring gas does not build up.

3 Turn on the gas to the fireplace. Turn on gas to the heater. Leak test all gas joints prior to starting the appliance. Start the pilot. Start the main burner. Leak test all gas joints again.

- 4 Replace the glass frame (and arch covers when using arched faces - see page 27).
- 5 Install the faceplate following the instructions included with the faceplate.
- ! **ACID WASH WARNING:** Before installing the faceplate, make sure any masonry that has been treated with acid wash has been properly neutralized (this is used primarily with brick faces). Acid wash (muriatic acid) is used to remove excess mortar. If not properly neutralized with an ammonia solution, the gold face may develop a permanent tarnish when the acid evaporates over time. Contact your dealer if uncertain your facing has been properly neutralized.
- 6 Check the pilot flame to make sure it looks like the illustration below. Adjust the pilot flame if necessary.

To adjust the pilot flame, turn this screw (NOTE: if totally unscrewed gas will come out of this port). Clockwise lowers the flame while counter-clockwise raises it.

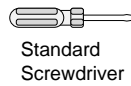

The pilot flame must contact the thermocouple and thermopile (see the illustration below). Adjust the pilot up or down as necessary.

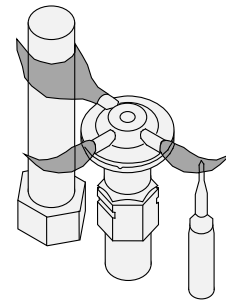
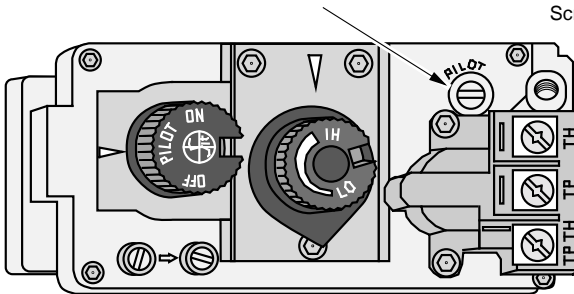

- 7 Let the heater burn for fifteen minutes. Adjust the air shutters, if necessary, to achieve the correct looking flame (see the illustration below).
 - The air shutter adjusts the amount of air that mixes with the gas before it exits the burner holes.

ADJUSTING THE AIR SHUTTERS

Pushing the control to the left gives the flame less air (making it more orange). Pushing to the right gives the flame more air, making it more blue. For fine adjustments use a screwdriver to tap the air shutter.

NOTE: If the air shutter is all the way open, yet the flames remain sooty, shut off gas to the fireplace and contact a qualified gas service technician.

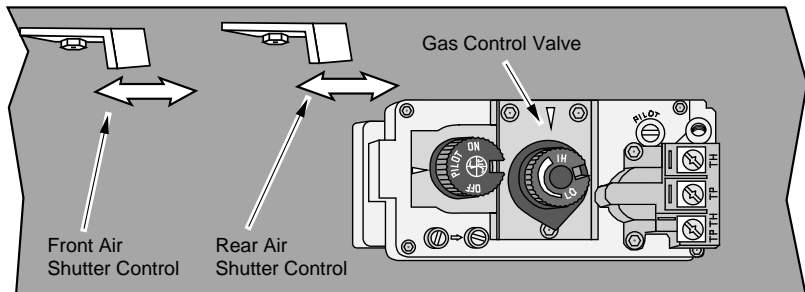

NOTE: The logs must be installed correctly to monitor the flame while adjusting the air shutter.



Correct

Flames should be blue at the base, yellow-orange on the top.

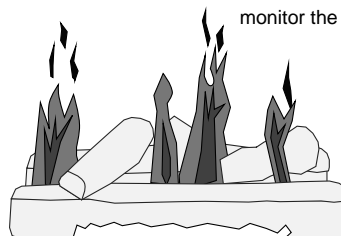

Not Enough Air

If the flames are over 14" tall or sooty on the ends, open the air shutter.

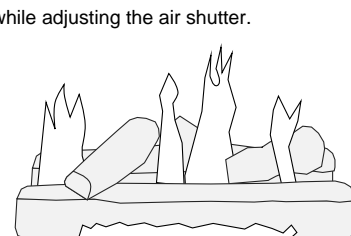

Too Much Air

If the flames are all blue and short, close the air shutter.

- 8 Turn the flame adjust knob to its highest position - the flames should be approximately 10" tall. Check the flame on low position. The flames should burn off of each burner hole. If the heater does not work correctly, contact your dealer for a remedy.

FINE TUNING THE EMBER-FYRE™ BURNER

Each installation is affected by altitude, vent configuration, and fuel quality. Because of this, the restrictor and air shutter may need to be fine tuned to each installation. Follow the hints below to fine-tune the burner for optimum performance and aesthetics.

Restrictor Hints:

Set the restrictor to the position suggested in the vent configuration table (see pages 20-23). Turn the heater on and allow it to reach full temperature (15 min.). If the flames indicate there is excessive draft due to altitude or climate, you may wish to adjust the restrictor to a more restrictive position (higher number). Active, flickering short flames are an indication of excessive draft. If the flames lift off of the burner holes, this indicates not enough draft (restrictor is set too high). After adjustments are made the unit must be cooled down to room temperature and restarted to make sure that the restriction is not so severe that the pilot will drop out when it is restarted. If the pilot does drop out reduce the restriction until it will operate continuously.

Air Shutter Hints:

- For more glow, open the air shutter, however, this will make the flames more blue.
- For yellow flames, close the air shutter, however, this may create less glow.

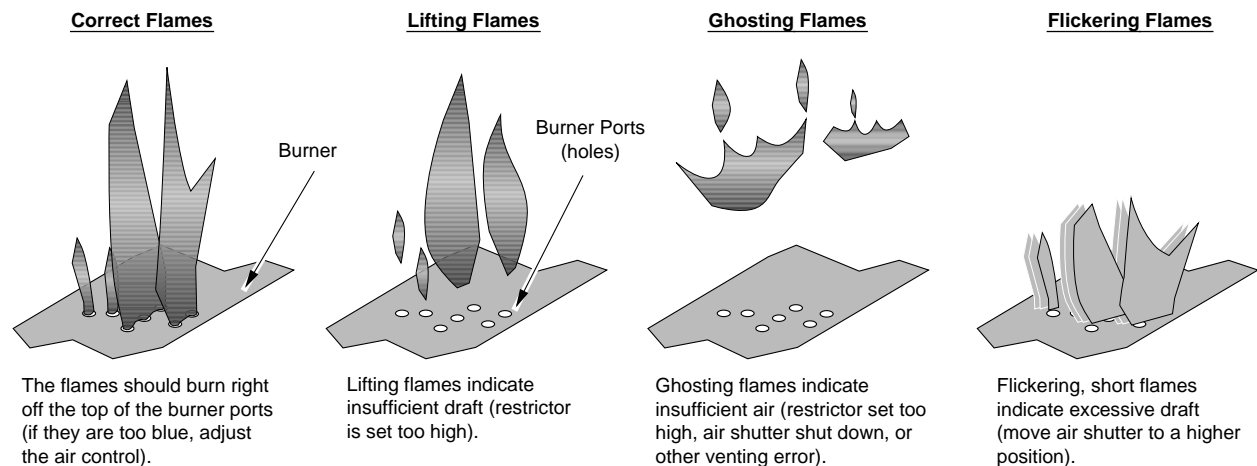

Warning: If the vent configuration is installed incorrectly the vent may cause the flames inside the heater to lift or "ghost" – a dangerous situation. Inspect the flames after installation to insure proper performance. If the vent configuration is correct, yet the flames are lifting or ghosting, shut off gas to the heater and contact the dealer for information on remedying the problem.

- 9 Give this manual to the home owner and fully explain the operation of this heater.

Before You Begin

! Read this entire manual before you use your new fireplace (especially the section "Safety Precautions" on pages 4 & 5). Failure to follow the instructions may result in property damage, bodily injury, or even death.

Location of Controls - See explanation below

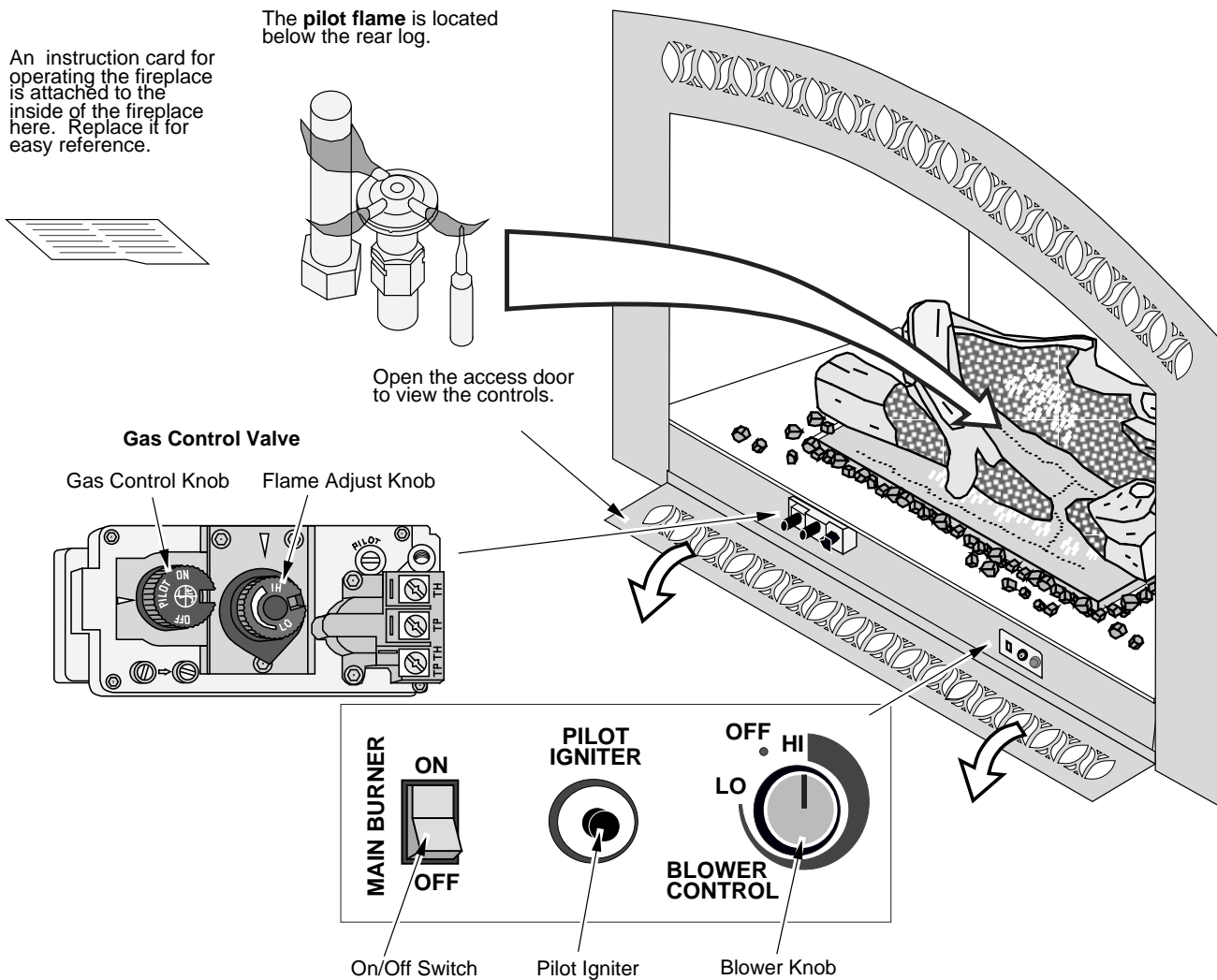

Blower Knob This knob controls the speed of the internal convection blower that pushes the heated air into the room.

On/Off Switch This control is used to turn the fireplace on and off.

Pilot Igniter The pilot igniter is used only to start the pilot. When pressed, it sends an electrical charge to the pilot assembly. This creates a blue spark directly next to the pilot, igniting the pilot flame.

Gas Control Knob This knob is used to control gas to the fireplace and for starting the pilot. There are three positions, ON, OFF, & PILOT. The pointer to the left of the knob indicates the position this knob is in.

Flame Adjust Knob This knob controls the flame height from low ("LO") to high ("HI"). The pointer above the knob points to the position this knob is in.

Starting The Pilot Flame

The pilot flame is required to ignite the main burners (it also plays a safety role). It should be left on once lit. It will stay lit unless the gas control valve is turned to "OFF". However, the pilot will go out if the gas is shut off, the propane tank runs out (or low) or if the stove malfunctions. If the pilot turns off frequently, call your dealer for information. To start the pilot follow the directions below:

WARNING:

When lighting or re-lighting the pilot, the glass must be removed (see page 27).

- a Remove the glass (see page 27 for details).
- b Push the gas control knob in slightly and turn it to the "OFF" position. The knob will not turn from "ON" to "OFF" unless the knob is depressed slightly. Wait five minutes to let any gas that may have accumulated inside the firebox escape. If you smell leaking gas, follow the directions on the cover "IF YOU SMELL GAS".
- c Turn the gas control knob to the "PILOT" position and press the knob in, this will allow gas to flow to the pilot light. Press the button on the pilot igniter repeatedly until you see the pilot light.

WARNING:

If the pilot does not light after 15 seconds, release the knob and call your dealer for service. Do not attempt to light pilot until service has been performed.

NOTE:

You may wish to remove the log set to gain a better view of the pilot (see page 28).

- d Keep the gas control knob depressed for 30 seconds once it is lit.
- e Release the gas control knob. If the pilot goes out, repeat step C. If the pilot refuses to stay lit, call your dealer for service. With the pilot lit, proceed to step "f".
- f Replace the glass.
- g Turn the gas control knob counter-clockwise to "ON". The pilot is now lit and the heater can be turned on and off.

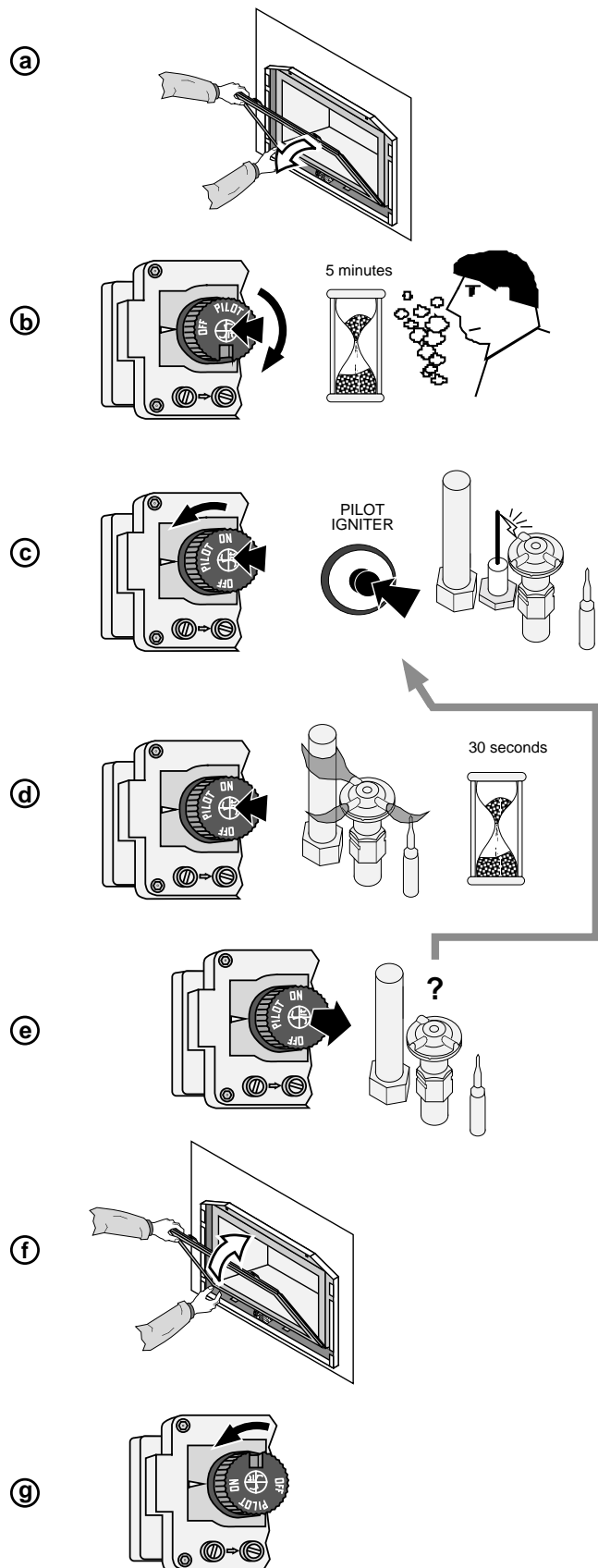

Starting the Fireplace for the First Time

- + Burn the heater at a high setting with the blower off for an extended period (up to 48 hours). This will cure the painted surfaces. **Fumes** from the paint curing and oil burning off the steel will occur. This is normal. We recommend opening a window to vent the room.
- + **Condensation** may appear on the glass each time you start the fireplace - this is normal.
- + **Blue Flames** will occur on the fireplace when it first comes on. After fifteen minutes the flames will turn a more realistic yellow and orange color.
- ? Certain installations use a remote "wall switch" to turn the fireplace on and off. If this is the case, leave the ON/OFF switch "ON".

Turning the Fireplace On and Off

After the pilot has been started...

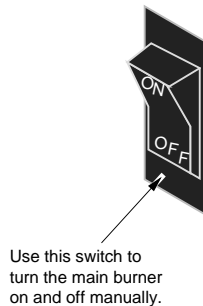

See the instructions included with the remote for details on operation.

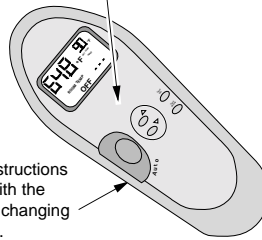

For systems with wall thermostats, use this switch to control the temperature (right is hotter, left cooler). Some systems require the on/off switch to be on.

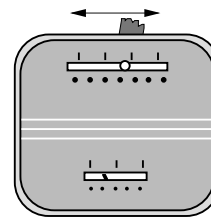

- ! Do not place any combustible items on top of or directly in front of the fireplace, even temporarily. The optional thermostat may start the fireplace causing a combustible item to ignite.
- ? If the fireplace turns on and off frequently while using the thermostat, you may want to adjust the flame height down until it produces just enough heat needed.

Adjusting the Flame Height

- + Your fireplace has an adjustable flame to tailor the look and heat output to your specific needs. It is adjusted by turning the middle dial on the gas control valve.

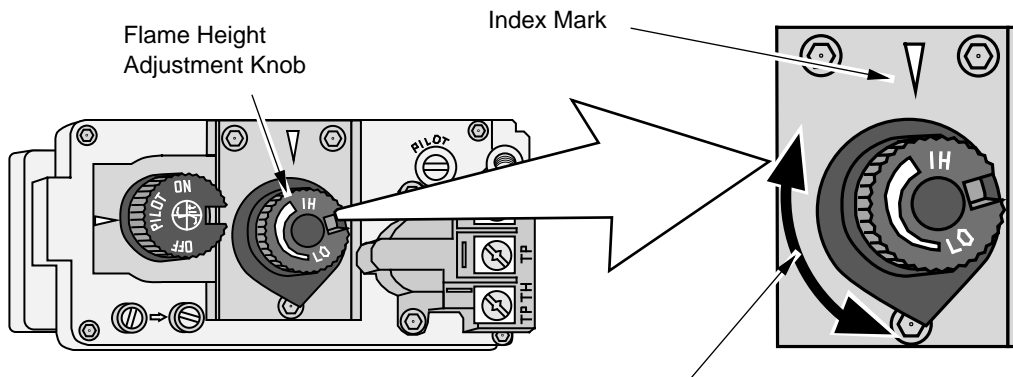

Turn counter-clockwise to adjust the flame higher, clockwise to lower.

Adjusting the Blower Speed

The internal blower helps transfer the heat from the fireplace into the room. It will not turn on until the fireplace is up to temperature (approximately 10 minutes after starting). See the illustration below for instructions on adjusting the blower speed.

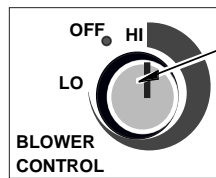

Blower Knob

Turn the knob all the way counter-clockwise to turn the blower off. One click clockwise turns the blower to high speed. Turning the knob clockwise from the high position decreases the speed of the blower.

Optional Power Heat Duct

Allow the fireplace to reach normal operating temperature. Then use the wall-mounted rheostat to operate the blower speed. The blower will automatically shut off after the fireplace cools.

OFF

Turn the dial all the way counter-clockwise until it clicks off.



HIGH

The high position is all the way counter-clockwise, **without** clicking off.

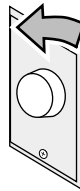

LOW

Turn the dial all the way clockwise.

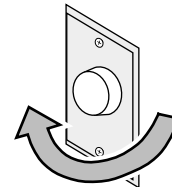

Normal Operating Sounds

The appliance will creak with change of temperature.

Pilot Flame

The pilot flame, which remains on, makes a very slight "whisper" sound.

Gas Control Valve

As the gas control valve is turned on and off you will hear a dull clicking sound. This is the valve opening up and shutting down.

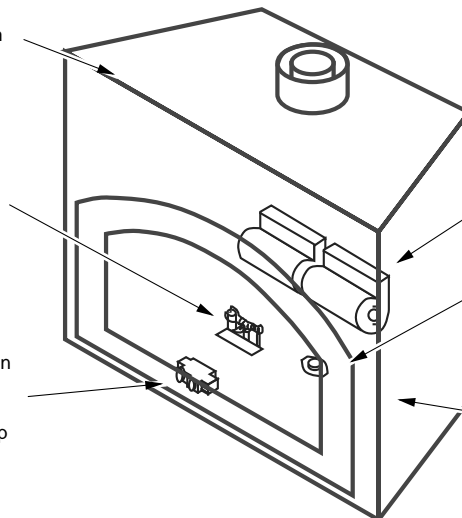

Blower

This heater uses a blower to push heated air into the room. You will hear the sound of air movement that increases as the speed is increased.

Blower Snap Disk

This part can produce a clicking sound as it turns the blower on and off.

Extinction Pops

It is not unusual, especially on Propane (LP) appliances, to experience a "pop" when the burner is shut off.

Normal Operating Odors

This appliance has several areas that reach high temperatures. Dust or other particles on these areas may burn and create an odor. This is normal during start-up. You may notice the smell is more acute if the appliance was left idle for a long period.

Maintaining Your Fireplace's Appearance

- ! Fingerprints or other marks left on the optional gold surface may become etched in place if they are not wiped clean prior to turning the fireplace on. Clean the gold with denatured alcohol and a soft cloth (with the fireplace cool). Other cleaners may leave a film that may become etched into the gold.

Yearly Service Procedure

- ! Failure to inspect and maintain the fireplace may lead to improper combustion and a potentially dangerous situation. We recommend the following procedures be done by a qualified technician.
- 1 Check the pilot flame. It should touch approximately 3/8" of the top of the thermopile and touch the top of the thermocouple (see illustration below). If it does not, contact your dealer for service.
- 2 Shut off gas to the fireplace by turning the gas control knob to "OFF" (see step A under "Starting the Pilot" on page 34). Let the fireplace cool for 15 minutes. Remove the faceplate (see instructions included with face) and glass (see page 27).
- 3 Remove the log set (**NOTE: the logs are very fragile** - see page 28). If severely deteriorated, replace. Check the logs for sooting. A small amount of soot along the bottom of the logs is normal. If excessive sooting is found, the fireplace will require adjustment. Contact your dealer.
- 4 Clean the burner (especially the burner holes) and inspect the following:
 - Check for burner pan holes that are cracked, severely warped, or corroded.
 - Make sure the burner assembly is not warped or damaged.
 - Check the firebox and area around the pilot to make sure there is no warping or damage.
 If any problem is found, discontinue use and contact your dealer for service.

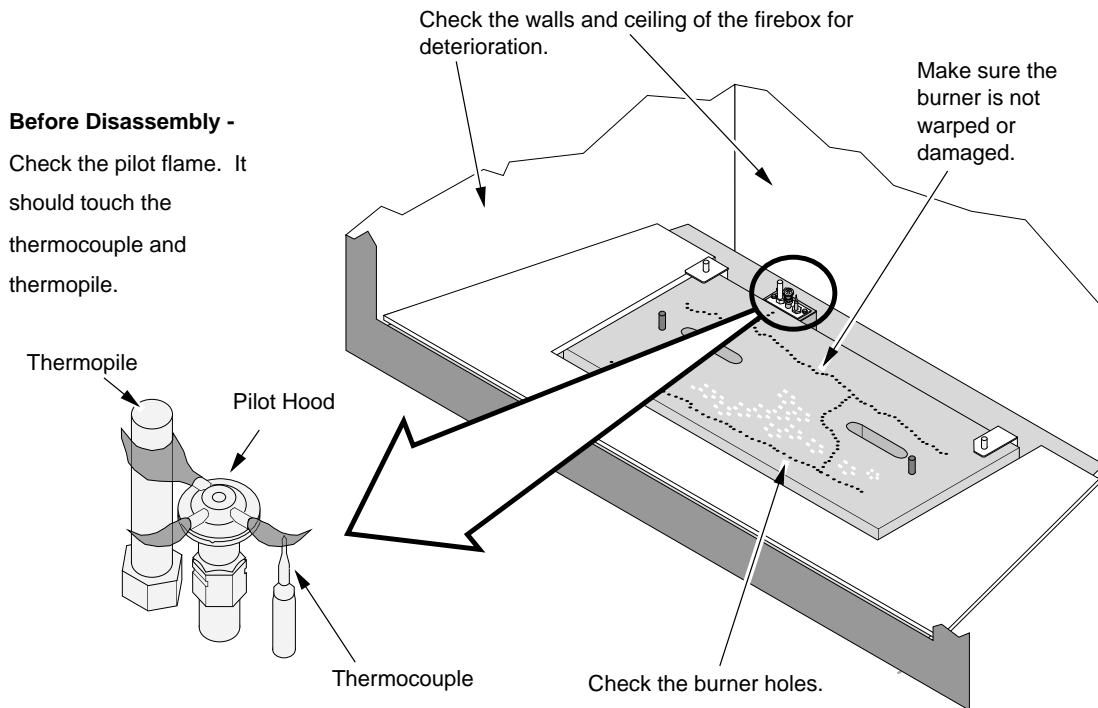

- 5 Replace the log set. Replace the glass (if the glass is damaged, replace it). Make sure the gasket along the perimeter of the glass contacts the face of the firebox and forms an air-tight seal. If it does not, re-align or replace the gasket to insure an air-tight seal. Replace the faceplate.
- 6 Inspect behind the access door. Clean if necessary. Check the gas control valve and gas lines. If damage is found, discontinue use and contact dealer for service. Clean the air channels and ducts.
- 7 Start the pilot and turn on the main burner. The flames should be orange/yellow and not touch the top of the firebox. If the pilot or main burners do not burn correctly, contact your dealer for service. Monitor the blower operation.
- 8 Remove any debris or vegetation near the vent termination. Contact your dealer if any sooting or deterioration is found near the vent termination.

Troubleshooting Table

Problem:	Possible Cause:	Don't Call for Service Until You:
Pilot Will Not Light	A gas shut off valve is turned off	Check all gas shut off valves
	The gas control knob isn't turned to "PILOT"	See "Starting the Pilot Light" Step C
	The valve control knob isn't pushed in	See "Starting the Pilot Light" Step C
	The igniter wasn't pressed repeatedly	See "Starting the Pilot Light" Step C
	No Propane in Tank	Check Tank Level
Main Burners Will Not Start	The pilot light has gone out	See "Starting the Pilot Light"
	The gas control valve is turned to "PILOT" or "OFF"	See "Starting the Pilot Light"
	The ON/OFF switch is turned to "OFF"	Turn the ON/OFF switch to "ON"
	The remote control is not working correctly	See the remote control instructions
	The thermostat is disconnected or set too low	See "Thermostat Operation"
Remote Control Does Not Work	The pilot light has gone out	See "Starting the Pilot Light"
	The gas control valve is turned to "PILOT" or "OFF"	See "Starting the Pilot Light"
	The ON/OFF switch is turned to "OFF"	Turn the ON/OFF switch to "ON"
	The remote is too far away from the fireplace	Use the remote closer to the fireplace
	The remote control receiver is turned "Off"	See the remote control instructions
	One of the two remote control batteries is dead	See the remote control instructions
Thermostat Does Not Work	The pilot light has gone out	See "Starting the Pilot Light"
	The gas control valve is turned to "PILOT" or "OFF"	See "Starting the Pilot Light"
	The ON/OFF switch is turned to "OFF"	Turn the ON/OFF switch to "ON"
	The thermostat is set too low	See "Thermostat Operation"
Fireplace Will Not Distribute Heat	The fireplace is not getting electricity	Check the breaker switch
	The fireplace is not up to temperature	See "Operating Your Fireplace"
Pilot Goes Out Once A Month Or More	The gas supply has been shut off	Keep the gas supply turned on
Flames Are Too Blue	The fireplace has just been started	This is normal - see "Starting the Fireplace for the First Time"
	Improper air shutter adjustment	Adjust Air Shutter - contact your dealer
Flames Are Too Short (Under 6")	The flame height may be turned too low	Turn the flame height to "HI" - See "Adjusting the Flame Height"
Thin Layer of Soot Covers the Glass	The logs or coals are placed incorrectly	See "Log Set Installation and Removal"
	Improper air shutter adjustment	Adjust Air Shutter - contact your dealer

How this Fireplace Works

! This fireplace was designed with safety as the primary concern. Many of the components inside this fireplace are for safety purposes. Therefore, only certified gas service technicians should service this fireplace.

What Turns the Main Burners On and Off

This fireplace uses a millivolt system to control its operation (a millivolt is a very small amount of electricity). The thermopile and thermocouple generate electricity when heated by the pilot flame. This electricity is used to operate the gas valve. Without enough electricity, the gas valve will not turn on. That is why when starting the pilot the gas control knob has to be pressed in long enough for the thermocouple to heat up and generate enough electricity. The thermopile provides power for the ON/OFF switch, remote control, or thermostat (see the illustration below). Because the thermopile generates the electricity needed to turn the fireplace on and off, this fireplace can be operated when the power is out (although the blower will not run).

When heated, the thermopile generates electricity (a very small amount measured in "Millivolts").

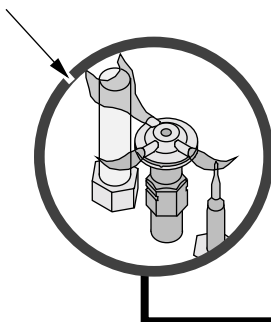

This electricity is used to operate the main burners.

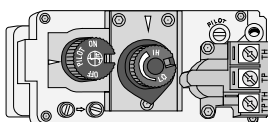

The main burners are switched on and off using the electricity generated by the thermopile. The ON/OFF switch, remote control, or thermostat control the circuit to the main burner.

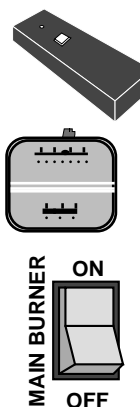

What Prevents Gas Buildup

- + This appliance utilizes a high-technology gas valve in conjunction with a pilot flame to ensure no gas builds up inside the firebox.
- + The thermocouple (next to the pilot) senses when the pilot flame is lit. If the pilot flame goes out, this thermocouple no longer generates electricity, causing the gas valve to automatically shut off all gas to the heater, preventing the pilot from spilling gas into the firebox.

Pilot Flame

The pilot flame is a time-proven component that eliminates the possibility of gas buildup inside the firebox.

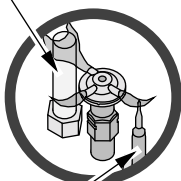

Thermocouple

The thermocouple generates a small amount of electricity. If the pilot flame goes out, the gas valve automatically shuts off all gas.

Gas Valve

This high-technology valve automatically shuts off all gas if it does not receive a signal from the thermocouple. If any component is damaged or sensing a malfunction, or if the wiring is damaged, it will shut off all gas.

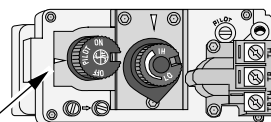

External Shut Off Valve

This valve is placed on the gas line to shut off gas to the appliance during maintenance procedures.

Ceramic Glass

The glass in your heater is the most durable glass available. It has been tested to be extremely resistant to breakage from temperature changes.

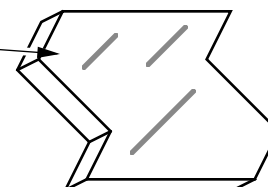

The safety (listing) label is adhered to the base of the fireplace near the gas control valve. A copy of the safety label is shown below.

Travis Industries Inc.
10850 117th Pl. N.E., Kirkland, WA 98033

Fireplace Xtracirclear 36 DV XL
 Direct Vent
 Vented Gas Fireplace Heater

Tested and certified by OMNI-Test Laboratories, Inc. to the combustion performance and construction requirements of ANSI Z21.88g-2000 and applicable sections of UL 307b. If any, if none, follow National Fuel Gas Code, ANSI Z223.1. This appliance must be installed in accordance with local codes. Manufactured Home Construction and Safety Standard, Title 24 CFR, Part 3280.

This appliance is only for use with the type of gas indicated on this rating plate and may be installed in an aftermarket, permanently located, manufactured (mobile) home where not prohibited by local codes. See owner's manual for details. This appliance is not convertible for use with other gases, unless a certified kit is used.

Vented Gas Fireplace Heater. Not for use with Solid Fuel.

The 36 DV XL is designed to operate on natural gas, or propane (LPG). THIS APPLIANCE IS FACTORY SET FOR USE WITH NATURAL GAS.

For conversion to Propane (LPG) use factory supplied kit. See owner's manual for information on making these changes.

WARNINGS:
 Improper installation, adjustment, alteration, service or maintenance can cause injury or property damage. Refer to the information in the owner's and installation manual provided with this appliance. For assistance or additional information consult a qualified installer, service agency or the gas supplier.
 Keep burner and control compartment clean. See installation and operating instructions accompanying appliance.
 This appliance must not be connected to a chimney flue servicing a separate solid fuel burning appliance.
 This vented gas fireplace heater is not for use with air filters.
CAUTION: Hot while in operation. Do not touch. Severe burns may result. Keep children, clothing, furniture, gasoline and other liquids having flammable vapors away.
CAUTION: Do not operate this appliance with glass removed, cracked or broken. Replacement of the panel should be done by a licensed or qualified service person.
 Only use direct vent systems listed in owner's manual to vent this appliance to the exterior (direct discharge only without duct connection).
 This appliance must be properly connected to a venting system in accordance with manufacturer's installation instructions.
WARNING: Operation of this appliance when not connected to a properly installed and maintained venting system can result in carbon monoxide (CO) poisoning and possible death.

Minimum Clearances to Combustibles

Fireplace to Adjacent Wall	4-1/2" (115mm)	Hearth Extension in Front	16" (406mm), 0" (0mm) if Fireplace Raised 3" (76mm)
Wood Floor Beneath Fireplace	0" (0mm)	Hearth Extension to Sides of Fireplace	0" (0mm)
Back to enclosure (from stand-offs)	0" (0mm)	Sides to enclosure (from stand-offs)	0" (0mm)
Top to enclosure (from stand-offs)	0" (0mm)	Fireplace to 8" Deep Mantel	22" (558mm) for Rectangular Faces, 24" (610mm) for Arched Faces*
		Flue Vent	See Owner's Manual

* See Owner's Manual For Additional Mantel Clearances and Options.

FAN TYPE VENTED CIRCULATOR

Blower Electrical Rating: 115 V, 1.5 Amps, 60 Hz, 150 watts

	L.P.	N.G.	L.P.	N.G.
Input Rate on "HI" (BTU/Hr)	43,000	43,000	Minimum Inlet Pressure (inches W.C.)	11.5" 5.5"
Input Rate on "LO" (BTU/Hr)	22,600	29,000	Maximum Inlet Pressure (inches W.C.)	13" 7"
			Manifold Pressure on "HI" (inches W.C.)	11" 3.5"

This appliance is equipped for installation in USA, 0-2000 ft. (0-610 m).
 In USA, for altitudes above 2,000 feet, the vent configuration, orifice, or combination of both may need to be changed.
 See the owner's manual for information on making these changes.

Manufacture: 2000 Jan. Apr. Jul. Oct.
 Date: 2001 Feb. May Aug. Nov.
 2002 Mar. Jun. Sep. Dec.

Travis Industries Inc.
10850 117th Pl. N.E., Kirkland, WA 98033 0322

To register your TRAVIS INDUSTRIES, INC. 7 Year Warranty, complete the enclosed Warranty card and mail it within **ten (10)** days of the appliance purchase date to: TRAVIS INDUSTRIES, INC., 4800 Harbour Pointe Blvd. SW, Mukilteo, WA 98275. TRAVIS INDUSTRIES, INC. warrants this gas appliance (appliance is defined as the equipment manufactured by Travis Industries, Inc.) to be defect-free in material and workmanship to the original purchaser from the date of purchase as follows:

**Check with your dealer in advance for any costs to you when arranging a warranty call.
Mileage or service charges are not covered by this warranty. This charge can vary from store to store.**

Years 1 & 2 - COVERAGE: PARTS & LABOR

Burner Assembly:

Burner, Air Shutter Assembly, Main Burner Orifice

Firebox Assembly:

Adjustable Air Restrictor, Pressure Relief Mechanisms, Glass Frame and Latch

Electrical Assembly:

Wiring harness, snap discs, Blower, Blower Rheostat

Gas Control Assembly

Adjustable control valve, millivolt wiring and connectors (located within the appliance), thermopile, thermocouple, pilot hood, orifices, pilot gas line, piezo ignitor

Ceramic Glass

Glass (breakage from thermal shock)

Ceramic Logs

Log Set, Coals, Ember Strip (Steel Fiber)

Accessories

Cast Fireback, Panels, Faceplate (see "Conditions and Exclusions" # 9)

Convection Heat Exchanger

Re-Installation Allowance

One-Way Freight Allowance

Exclusions: Paint, Gasketing

Years 3 THROUGH 5 - COVERAGE: PARTS & LABOR

Firebox Assembly:

Adjustable Air Restrictor, Pressure Relief Mechanisms, Glass Frame and Latch

Convection Heat Exchanger

One-Way Freight Allowance

Exclusions: Paint, Gasketing, Burner Assembly, Electrical Assembly, Gas Control Assembly, Ceramic Glass, Ceramic Logs, Accessories (Fireback, Panels, Faceplate), Re-Installation Allowance

Years 6 & 7 - COVERAGE: PARTS ONLY

Firebox Assembly:

Adjustable Air Restrictor, Pressure Relief Mechanisms, Glass Frame and Latch

Exclusions: Paint, Gasketing, Burner Assembly, Electrical Assembly, Gas Control Assembly, Ceramic Glass, Ceramic Logs, Convection Heat Exchanger, Accessories (Fireback, Panels, Faceplate), Re-Installation Allowance, One-Way Freight Allowance, Labor

CONDITIONS & EXCLUSIONS

- This new gas appliance must be installed by a qualified gas appliance technician. It must be installed, operated, and maintained at all times in accordance with the instructions in the Owner's Manual. Any alteration, willful abuse, accident, neglect, or misuse of the product shall nullify this warranty.
- This warranty is nontransferable, and is made to the ORIGINAL purchaser, provided that the purchase was made through an authorized TRAVIS dealer.
- Discoloration and some minor expansion, contraction, or movement of certain parts and resulting noise, is normal and not a defect and, therefore, not covered under warranty. The installer must ensure the appliance is burning as per the rating tag at the time of installation. Over-firing (operation above the listed BTU rate) of this appliance can cause serious damage and will nullify this warranty.
- The warranty, as outlined within this document, does not apply to the chimney components or other Non-Travis accessories used in conjunction with the installation of this product. If in doubt as to the extent of this warranty, contact your authorized TRAVIS retailer before installation.
- Travis Industries will not be responsible for inadequate performance caused by environmental conditions such as nearby trees, buildings, roof tops, wind, hills or mountains or negative pressure or other influences from mechanical systems such as furnaces, fans, clothes dryers, etc.
- This Warranty is void if:
 - The unit has been operated in atmospheres contaminated by chlorine, fluorine or other damaging chemicals.
 - The unit is subject to submersion in water or prolonged periods of dampness or condensation.
 - Any damage to the unit, combustion chamber, heat exchanger or other components due to water, or weather damage which is the result of, but not limited to, improper chimney/venting installation.
- Exclusions to this 7 Year Warranty include: injury, loss of use, damage, failure to function due to accident, negligence, misuse, improper installation, alteration or adjustment of the manufacturer's settings of components, lack of proper and regular maintenance, damage incurred while the appliance is in transit, alteration, or act of God.
- This 7 Year warranty excludes damage caused by normal wear and tear, such as paint discoloration or chipping, worn or torn gasketing, corroded or cracked logs, embers, etc. Also excluded is damage to the unit caused by abuse, improper installation, modification of the unit, drilling of the orifices, or the use of fuel other than that for which the unit is configured. Units are shipped for natural gas and must be converted to propane using the included conversion kit. Confirm fuel configuration with your installer.
- Damage to gold or nickel surfaces caused by fingerprints, scratches, melted items, or other external sources left on the gold or nickel from the use of cleaners other than denatured alcohol is not covered in this warranty.
- TRAVIS INDUSTRIES, INC. is free of liability for any damages caused by the appliance, as well as inconvenience expenses and materials. Incidental or consequential damages are not covered by this warranty. In some states, the exclusion of incidental or consequential damage may not apply.
- This warranty does not cover any loss or damage incurred by the use or removal of any component or apparatus to or from the TRAVIS gas appliance without the express written permission of TRAVIS INDUSTRIES, INC. and bearing a TRAVIS INDUSTRIES, INC. label of approval.
- Any statement or representation of TRAVIS products and their performance contained in TRAVIS advertising, packaging literature, or printed material is not part of this 7 year warranty.
- This warranty is automatically voided if the appliance's serial number has been removed or altered in any way. If the appliance is used for commercial purposes, it is excluded from this warranty.
- No dealer, distributor, or similar person has the authority to represent or warrant TRAVIS products beyond the terms contained within this warranty. TRAVIS INDUSTRIES, INC. assumes no liability for such warranties or representations.
- Travis Industries will not cover the cost of the removal or re-installation of hearths, venting or other components.
- If for any reason any section of this warranty is declared invalid, the balance of the warranty remains in effect and all other clauses shall remain in effect.
- This 7 year warranty is the only warranty supplied by Travis Industries, Inc., The manufacturer of the appliance. All other warranties, whether express or implied, are hereby expressly disclaimed and purchaser's recourse is expressly limited to the warranties set forth herein.

IF WARRANTY SERVICE IS NEEDED:

- If you discover a problem that you believe is covered by this warranty, you MUST REPORT it to your TRAVIS dealer WITHIN 30 DAYS, giving them proof of purchase, the purchase date, and the model name and serial number.
- Travis Industries has the option of either repairing or replacing the defective component.
- If your dealer is unable to repair your appliance's defect, he may process a warranty claim through TRAVIS INDUSTRIES, INC., including the name of the dealership where you purchased the appliance, a copy of your receipt showing the date of the appliance's purchase, and the serial number on your appliance. At that time, you may be asked to ship your appliance, freight charges prepaid, to TRAVIS INDUSTRIES, INC. TRAVIS INDUSTRIES, INC., at its option, will repair or replace, free of charge, your TRAVIS appliance if it is found to be defective in material or workmanship within the time frame stated within this 7 year warranty. TRAVIS INDUSTRIES, INC. will return your appliance, freight charges (years 1 to 5) prepaid by TRAVIS INDUSTRIES, INC., to your regional distributor, or dealership.
- Check with your dealer in advance for any costs to you when arranging a warranty call. Mileage or service charges are not covered by this warranty. This charge can vary from store to store.

LP Conversion Instructions

Install the conversion kit prior to installing the gas line to ensure proper gas use.

- 1 Remove the glass (see page 27). Remove the logs and coals (if installed - page 28)
- 2 Remove the burner (see illustration below).

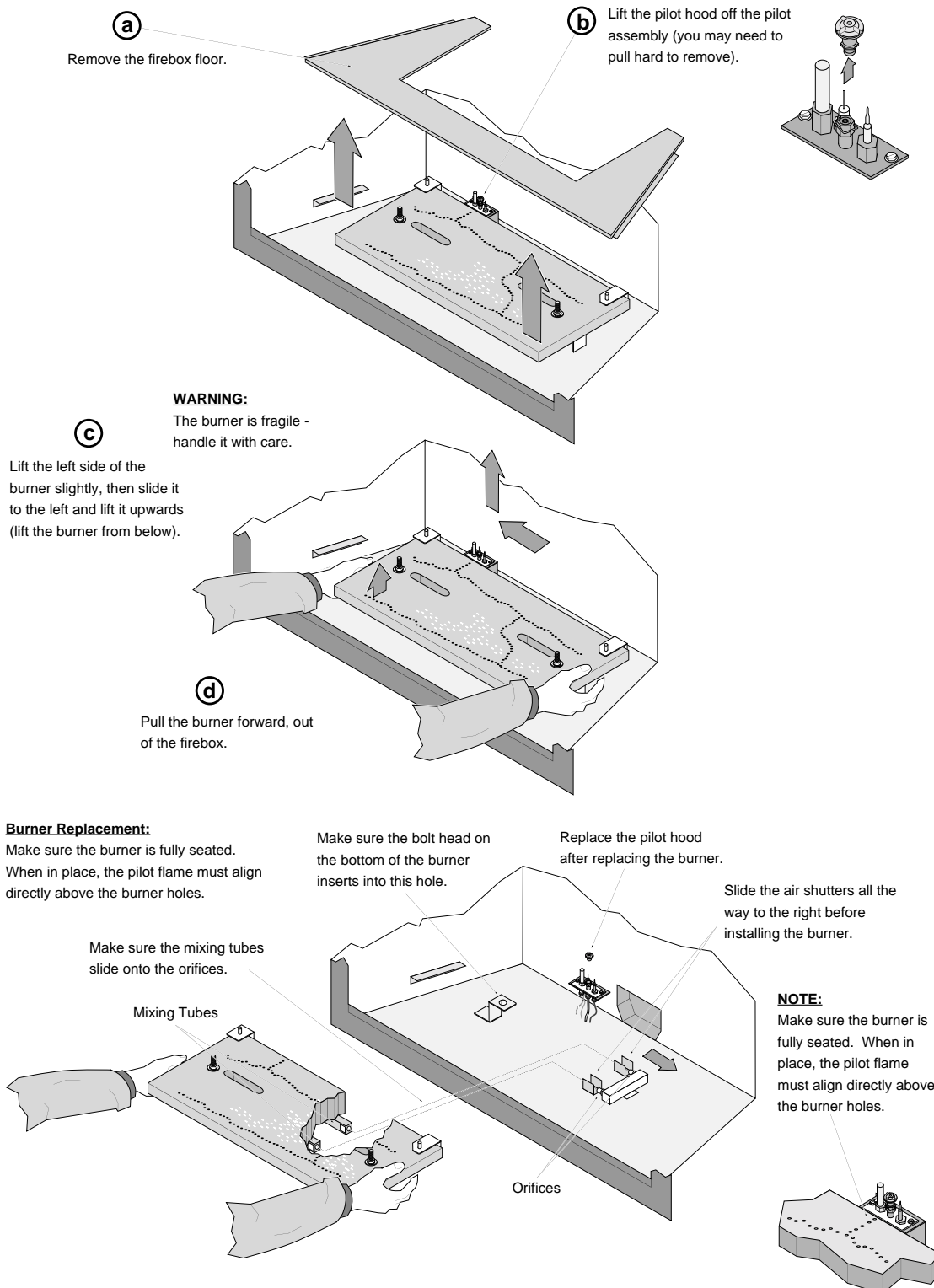

44 Optional Equipment

(for qualified installers only)

3 Follow the directions below to replace the orifices.

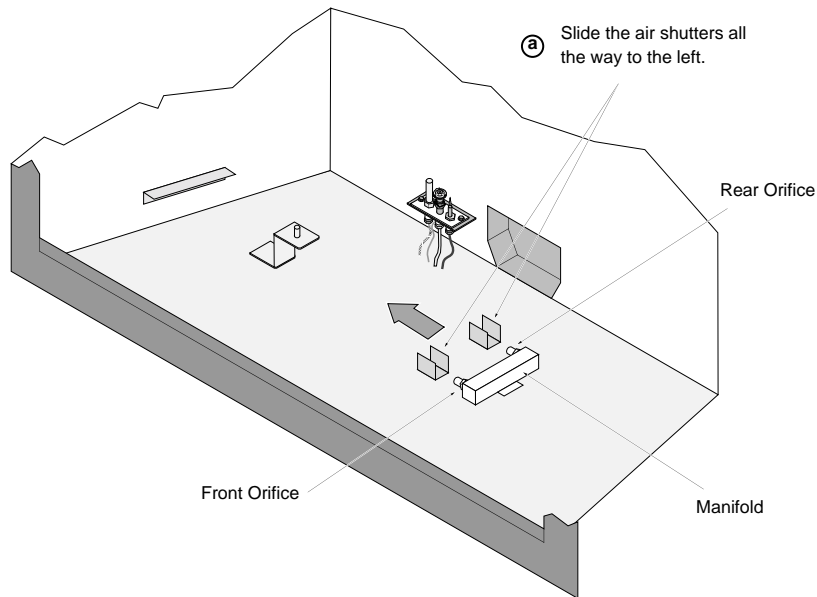

a Slide the air shutters all the way to the left.

b Use a 1/2" open end wrench to unscrew both orifices.

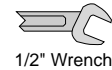

1/2" Wrench

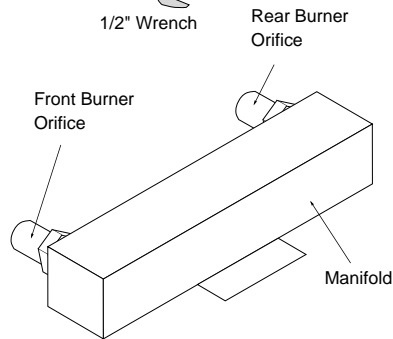

c Apply thread sealant to the LP orifices prior to installation. Use the chart below to identify the correct orifices.



	LP	NG
Front	#55	#46
Rear	#54	#43

d Screw the LP orifice in so the orifice shoulder protrudes 5/16" (indicating full insertion).

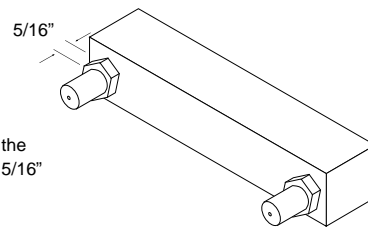

4 Remove the pilot orifice following the instructions below. Replace with the propane pilot orifice

a Lift the pilot hood off the pilot assembly.

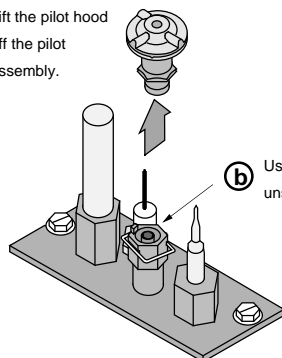

b Use a hex wrench to unscrew the orifice.



5/32" Hex

c Remove the orifice and replace with the LP orifice. Screw the orifice all the way in and replace the pilot hood.

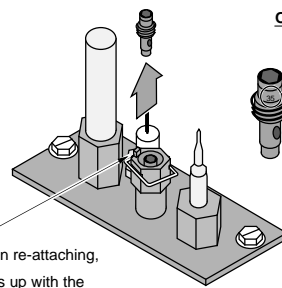

Orifice Identification:

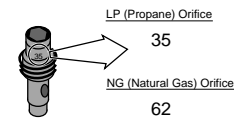

NOTE: when re-attaching, this pin lines up with the notch in the pilot hood.

- 5 Install the logs and embers.
- 6 Replace glass and face.
- 7 Remove the regulator from the front of the gas control valve. Replace with the propane regulator, using the new gasket and screws included with the regulator.
NOTE: Leak test this area after the heater is installed, gas is connected, and the main burner is lit.

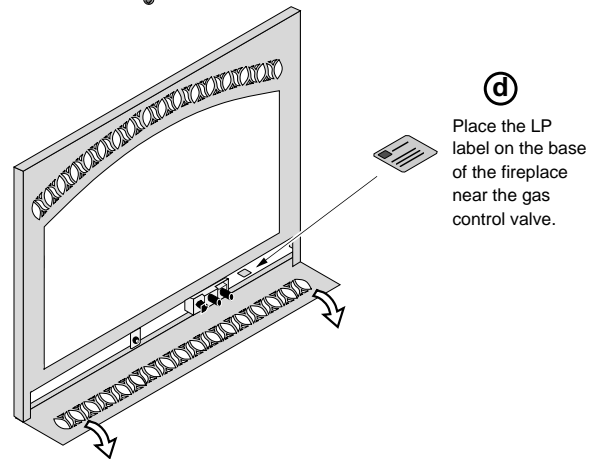
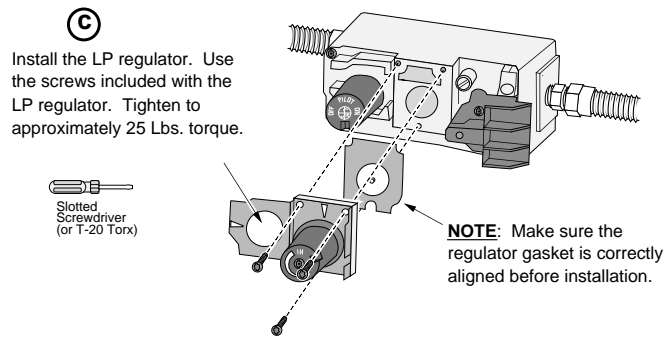
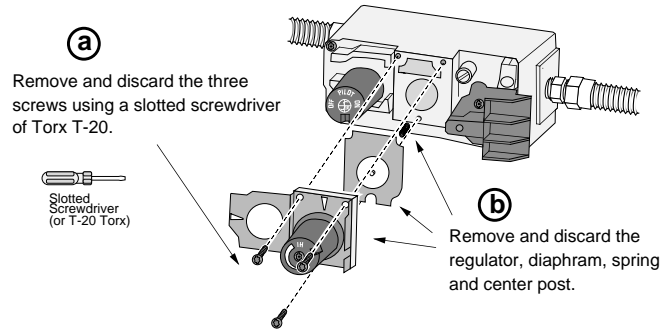

- 9 Make the gas line connection, bleed the gas line (if applicable), start the heater and thoroughly leak-test all gas connections and the gas control valve. Check the pilot. Adjust if necessary.

WARNING: When lighting or re-lighting the pilot, the glass must be removed (see page 27).

To adjust the pilot flame, turn this screw (NOTE: if totally unscrewed gas will come out of this port). Clockwise lowers the flame while counter-clockwise raises it.



The pilot flame must contact the thermocouple and thermopile (see the illustration below). Adjust the pilot up or down as necessary.

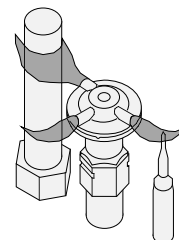
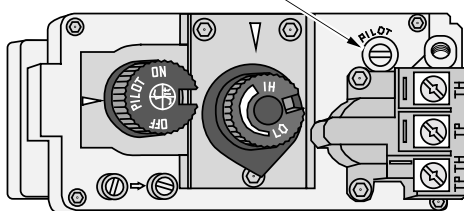

46 Optional Equipment

(for qualified installers only)

POWER HEAT DUCT (part # 98500769)

The optional heat duct allows the fireplace to transfer heat to separate locations in the home. **One or two ducts may be used.** Installation should take place prior installing drywall.

Warning: This kit must be installed as specified in these instructions. Do not modify any component.

Warning: Use of any external blower other than the Travis Power Heat Duct Blower will void the warranty and listing of this appliance and may create a fire hazard.

Note: The power heat duct **must** be installed by a qualified service technician.

Note: Some building codes may require the use of firestop spacers whenever the duct passes from room to room.

Note: When routing ducts through a cold area (e.g. crawl space) we recommend insulating the duct with fiberglass insulation. If paper-backed insulation is used, the paper can not contact the duct.

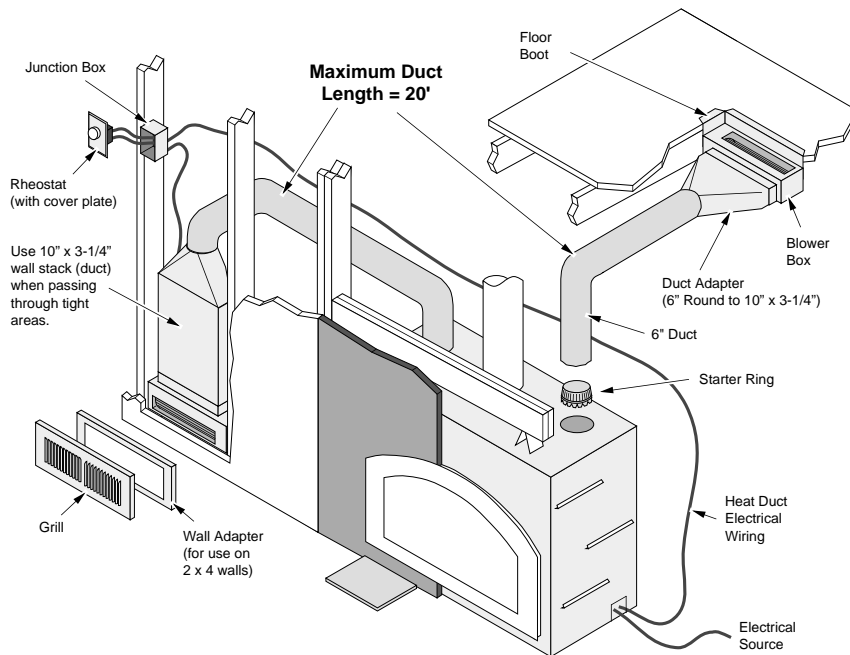

- Determine the route for the heat duct using the illustration below as a guide.

NOTE: Air flow through the duct is affected by length and number of bends. Keep the length and number of bends to the minimum to maximize performance.

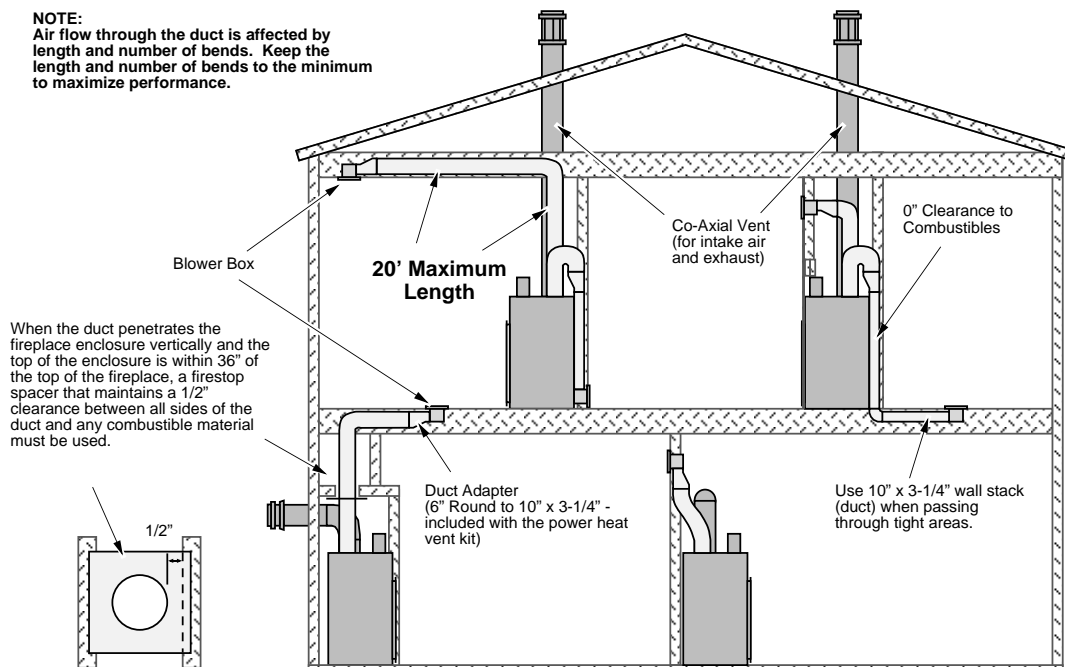

- Attach the blower box to the framing or floorboards of the home following the instructions below.

Wall or Ceiling Mounting

- (a)** Cut a hole between wall framing members for the blower assembly.

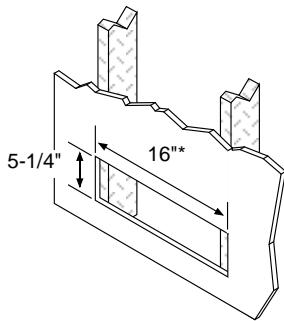

* This blower was designed for framing on 16" centers - construct additional framing if needed.

- (b)** Attach the wall mounting brackets to the blower box.

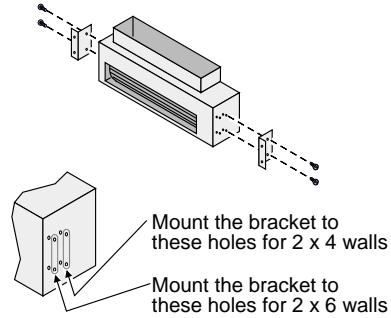

- (c)** Slide the blower, with wires, into the hole cut in step "a". Attach with four screws.

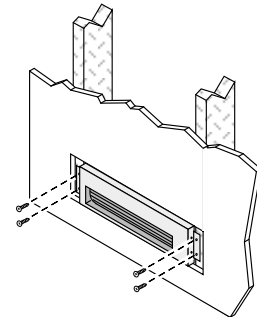

Floor Mounting

- (a)** Cut a hole between floor joists for the blower box.

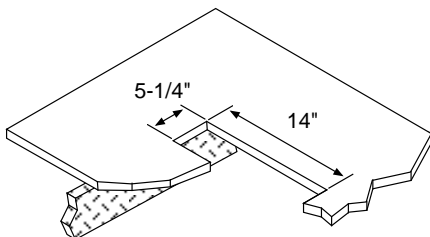

- (b)** Attach the floor boot to the blower box with the included screws.

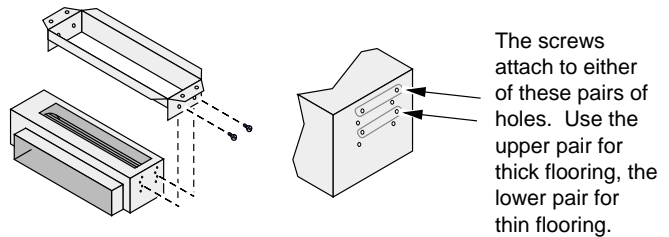

- (c)** Slide the blower into the hole cut in step "a". Attach with four screws.

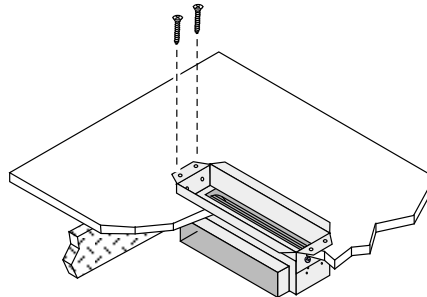

48 Optional Equipment

(for qualified installers only)

- Attach the starter ring to the fireplace following the directions below (use the most convenient side).

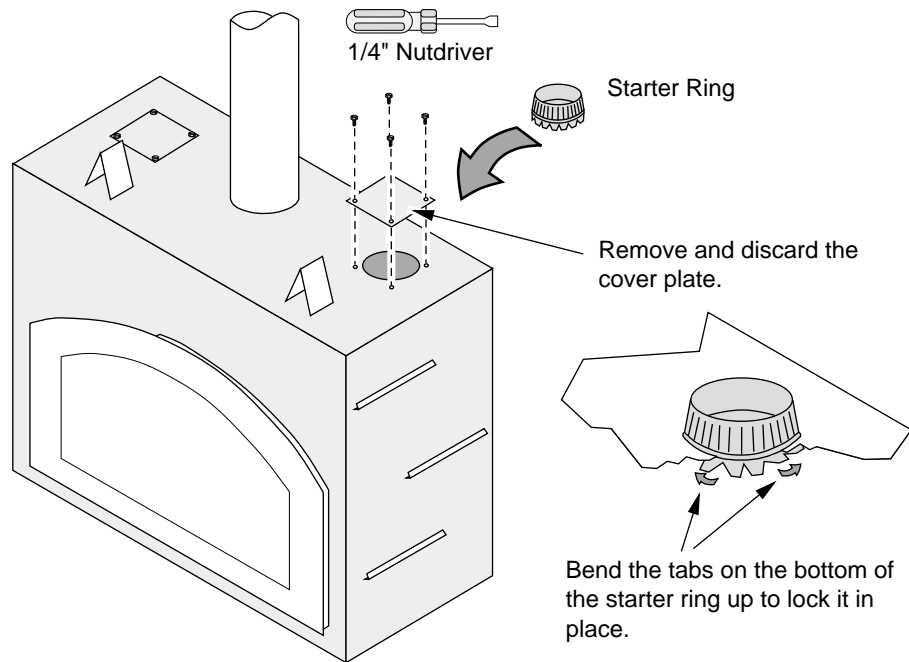

- Install the air duct. Each section, when joined, must be attached with three screws and duct tape (U.L. 181A-P or equivalent). Secure the duct if it is in an area where it may sag or become dislodged.

NOTE: The air duct has a 0" clearance to combustibles.

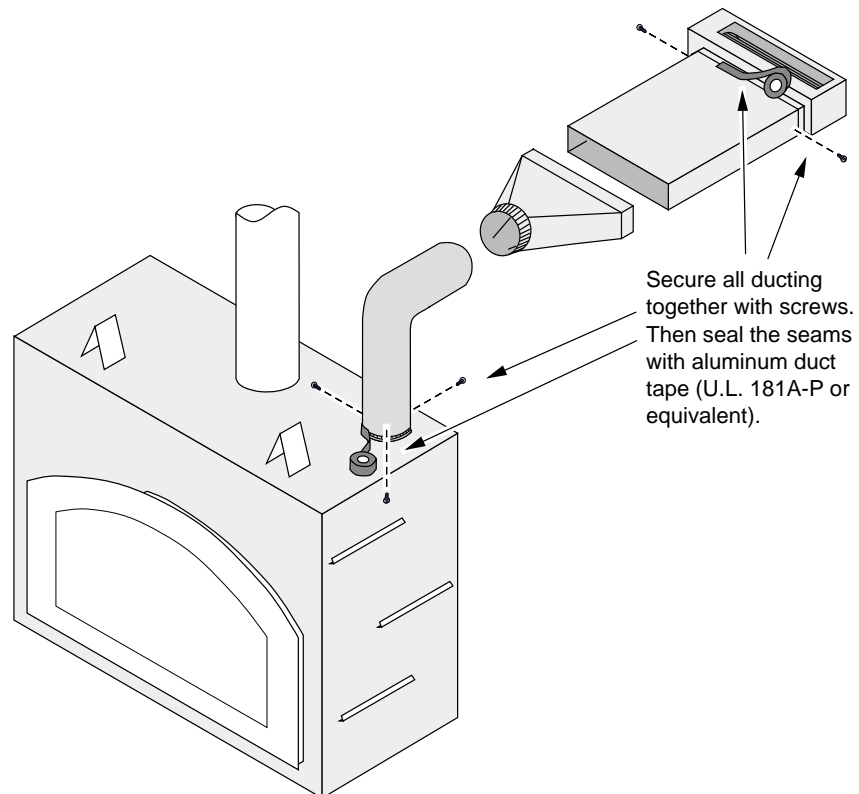

- Attach the grill (and wall adapter, if necessary).

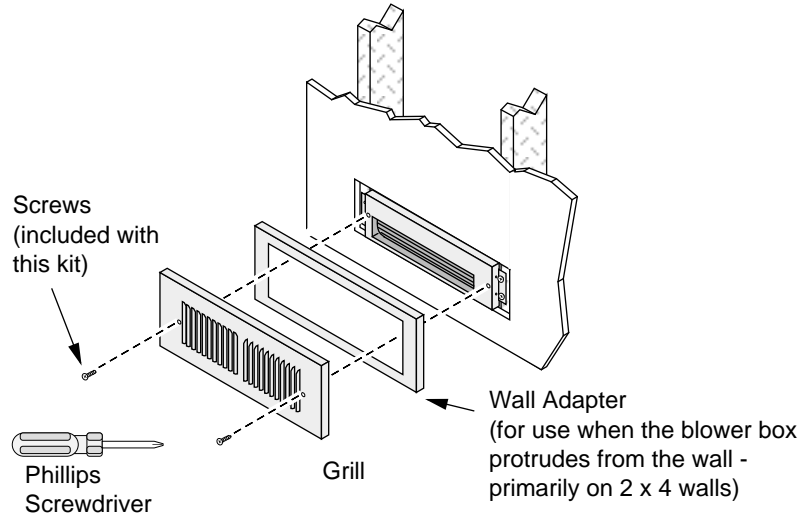

WIRING INSTRUCTIONS

Warning: All wiring should be done by a qualified electrician and shall be in compliance with local codes and with the current National Electric Code ANSI/NFPA 70 (in the U.S.), or with the current CSC22.1 Canadian Electric Code (in Canada).

Warning: Make sure the fireplace electrical circuit is disabled prior to working on electrical hookup.

Wiring Diagram

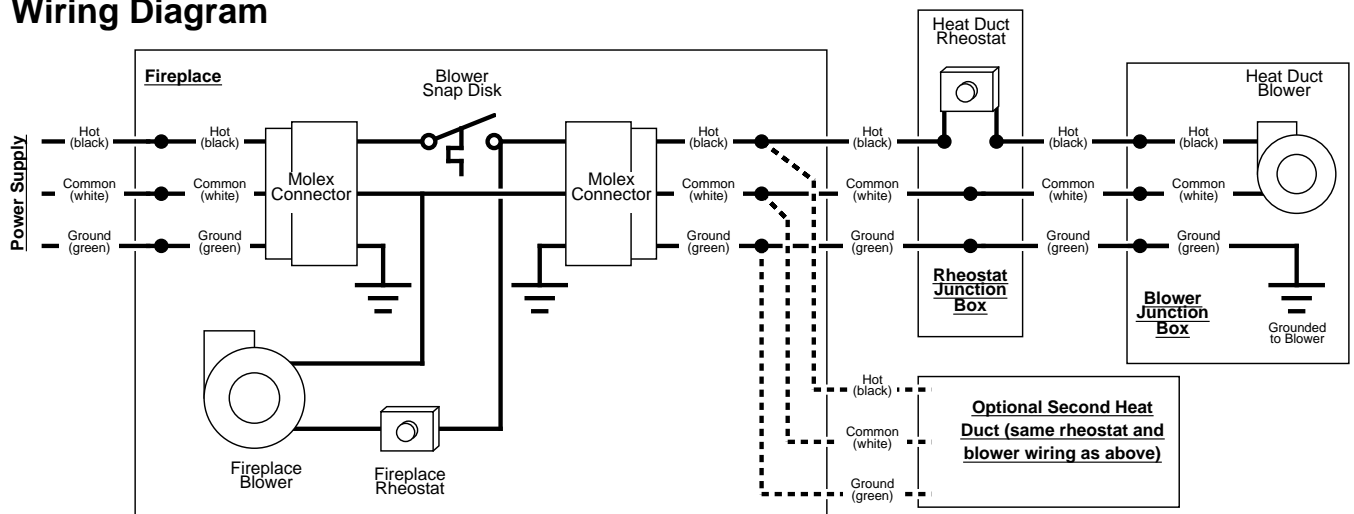

50 Optional Equipment

(for qualified installers only)

- Follow the directions below to wire the blower box.

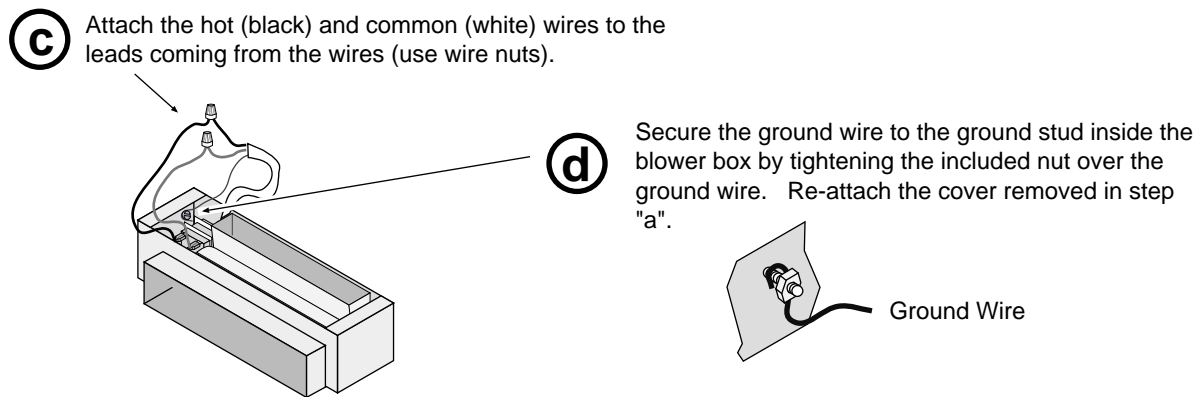
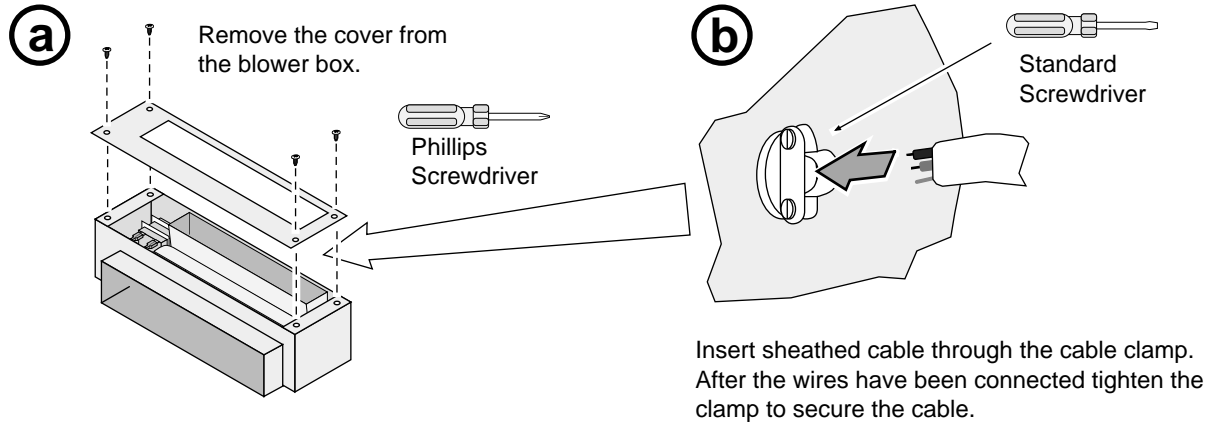

- Follow the directions below to wire the rheostat. **NOTE:** There are two types of junction boxes, use the appropriate junction box for your installation.

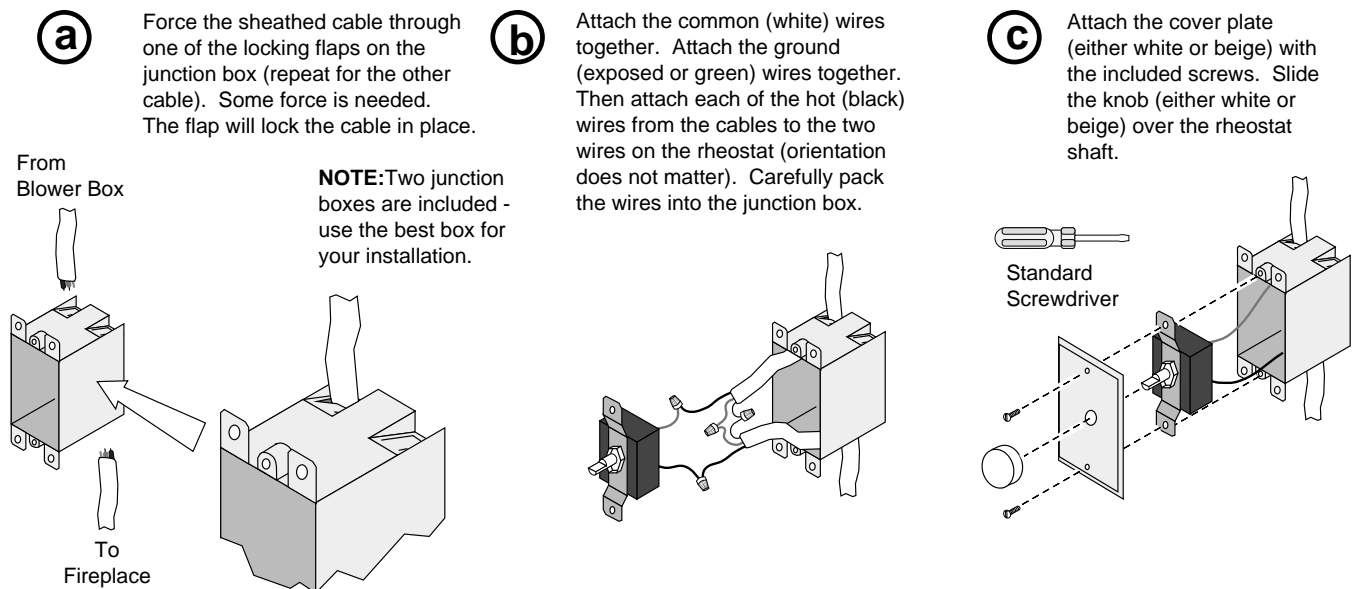

Optional Equipment (for qualified installers only) 51

- Run the free wire from the rheostat junction box to the fireplace. Follow the directions below to connect the heat duct circuit to the fireplace.

(a) Remove the cover from the fireplace junction box.

Note: you may need to loosen this cable clamp to ease removal of the cover plate.

(c) Insert the sheathed cable from the rheostat through a cable clamp and push the cable clamp into the knock-out hole to secure it in place. Once the wires are attached, tighten the clamp to secure the cable.

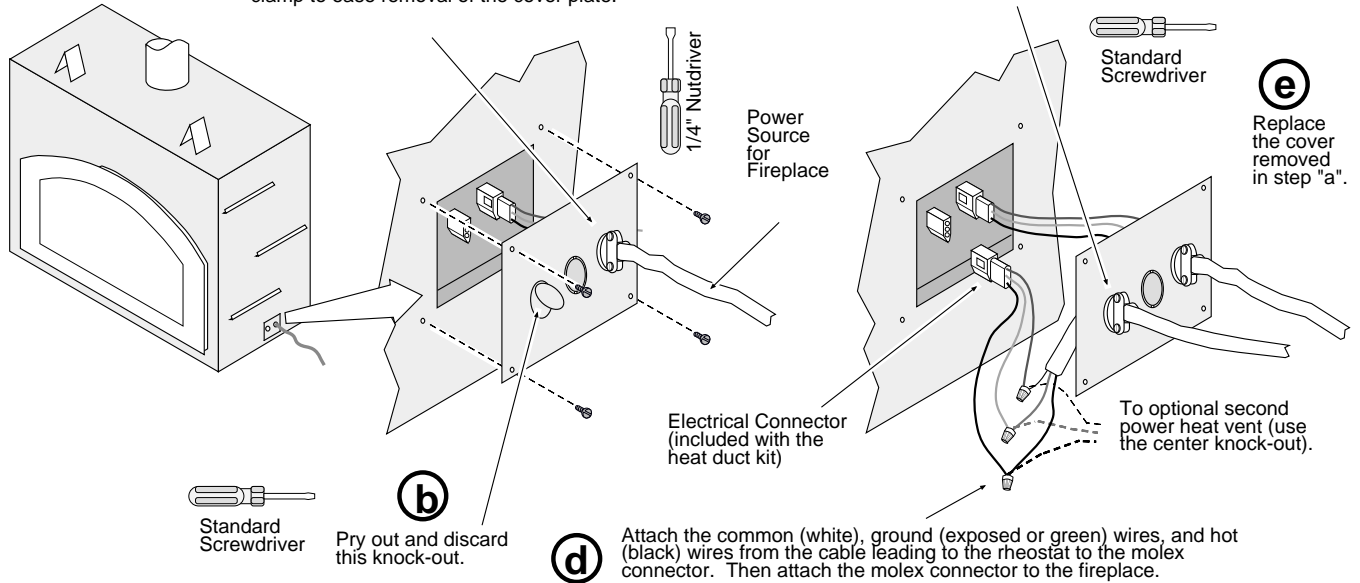

MAINTENANCE INSTRUCTIONS

Once a year the grate should be removed and the blower area cleaned. Use a vacuum to clean around the squirrel-cage blower, being careful not to damage any of the blades.

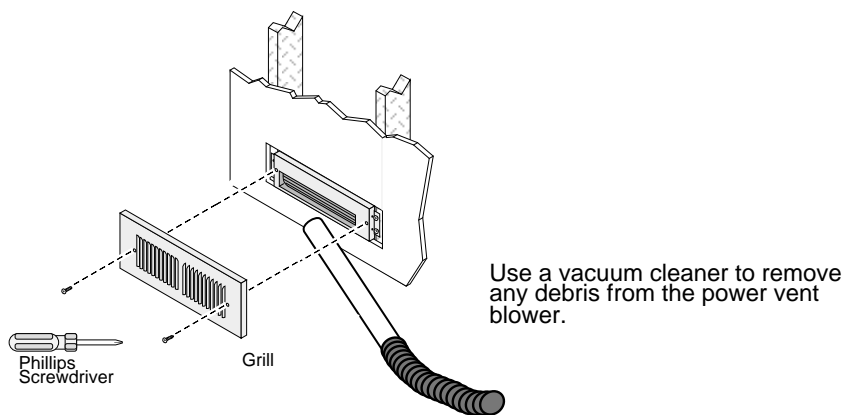

Approved Vent Configurations.....	18	Installation Options	5
Adjusting the Blower Speed.....	35	Items Required for Installation.....	6
Adjusting the Flame Height	34	Leaking Gas	See Inst. on Cover
Air Shutter Adjustment.....	31	Listing Information	40
Altitude Considerations.....	16	Location of Controls.....	32
Blower Control.....	35	Log Set Installation and Removal	27
BTU Input.....	5	Maintenance	36
BTU Output.....	5	Mantel Requirements.....	15
Cap (see vent termination).....	23	Measuring Vent Lengths.....	18
Chimney Cap (see vent termination).....	23	Noise (see Normal Operating Sounds)	35
Chimney Installation (see Vent Requirements)....	16	Normal Operating Sounds.....	35
Clearances.....	7	Packing List.....	6
Condensation on Glass.....	35	Pilot Flame Inspection.....	30
Corner Installation.....	8	Piping Installation (see Gas Line Install).....	24
Dimensions.....	5	Raised Fireplaces	8
Dura-Vent (part numbers).....	16	Restrictor Position	18
Elbows.....	18	Safety Label.....	40
Electrical Connection.....	25	Safety Precautions	2
Face Dimensions.....	12	Starting The Pilot.....	33
Face Installation.....	30	Starting the Fireplace for the First Time.....	34
Facing Requirements.....	10	Thermostat Operation.....	34
Finalizing the Installation.....	26	Turning the Fireplace On and Off.....	34
Floor Protection (see "Hearth Requirements")....	9	Vent Length (see "Vent Configuration").....	18
Framing Dimensions	7	Vent Part Numbers	18
Fuel.....	24	Vent Requirements	16
Gas Control Valve (Location).....	32	Vertical Vent Termination Requirements	23
Gas Inlet Pressure.....	24	Warnings.....	2
Gas Line Connection	24	Warranty.....	41
Gas Line Install.....	24	Water on Glass (see Condensation)	34
Gas Smell.....	See Inst. on Cover	Weight (250 Lbs.).....	5
Glass Installation and Removal	26	What Prevents Gas Buildup.....	38
Glass, Glass Gasket.....	26	What Turns the Main Burners On and Off.....	38
Hearth Requirements.....	9	Wiring Diagram.....	39
Heating Specifications	5	Yearly Service Procedure.....	36
Horizontal Vent Termination Requirements	23		
How this Fireplace Works.....	38		
Vent Lengths.....	18		